



Precision Gages Product Catalog



Mahr Precision Gages



Solutions for your measurement challenges

Innovative solutions for every measuring task, that's what Mahr offers you. All product combine proven precision and high efficiency to make your work as productive as possible

MarCal | The Calipers

Calipers are some of the most important measuring instruments in production metrology due to their versatility and ease-of-use. Digital devices are simple to operate and easy to read. In addition, they enable fast and uncomplicated data acquisition.

FUNCTIONS

- ON/OFF
- AUTO-ON / OFF
- HOLD (storage of measured values)
- RESET (set display to zero)
- PRESET (for entering a numerical value)
- Reversal of counting direction
- mm/inch
- LOCK function (key lock)

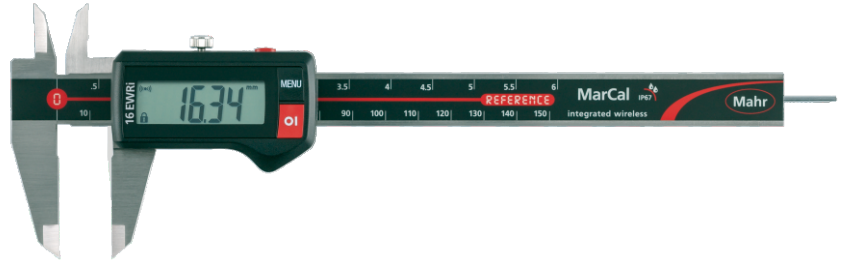

MarCal 16 ER Digital Caliper

With large digital display

Product	Measuring range		Resolution	Order No.
	mm	(inch)	mm/inch	
16ER	0-150	(6")	0.01/0.0005	4103010
16ER	0-200	(8")	0.01/0.0005	4103206
16ER	0-300	(12")	0.01/0.0005	4103208

MarCal 16 EWR Digital Caliper

Excellent protection against dust, coolants & lubricants

Product	Measuring range		Resolution	Order No.
	mm	(inch)	mm/inch	
16EWR	0-150	(6")	0.01/0.0005	4103300
16EWR	0-200	(8")	0.01/0.0005	4103304
16EWR	0-300	(12")	0.01/0.0005	4103306

MarCal 16 EWRI

Digital calipers with Integrated Wireless

Product	Measuring range		Resolution	Order No.
	mm	(inch)	mm/inch	
16EWRI	0-150	(6")	0.01/0.0005	4103401
16EWRI	0-200	(8")	0.01/0.0005	4103405
16EWRI	0-300	(12")	0.01/0.0005	4103407



i-stick
order no 4102220

MarCal 16 EWRI-V

Digital universal caliper

Product	Measuring range		Resolution	Order No.
	mm	inch	mm/inch	
16 EWR-V	0-200	0-8"	0.01/.0005"	4118807
16 EWRI-V	0-200	0-8"	0.01/.0005"	4118907

This option is also available in MicroMeter.

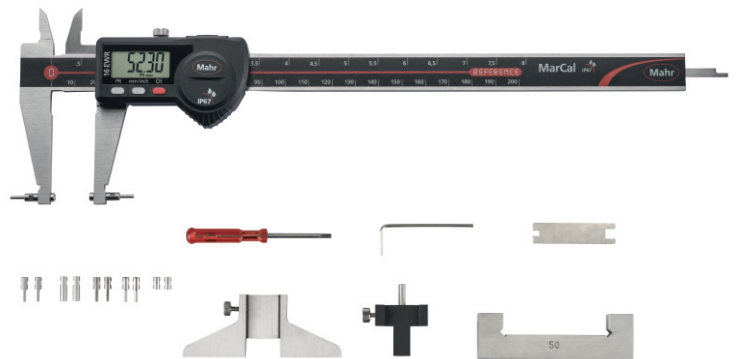
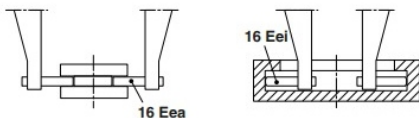

- For Wireless Data Transmission
- Industry 4.0 Compatible
- Software Marcom professional Free Download : www.mahr.com

Micromar | Everything Revolves Around Precision

Besides calipers, micrometers are the most frequently used hand measuring instruments. With precision-ground spindles, carbide-tipped measuring faces and a robust frame construction; the modern micrometer from the Mahr Micromar series ensures maximum precision and a long working life.



- High contrast display, digit height 10 mm
- Spindle is made from stainless steel, hardened and ground
- Rapid drive with Ratchet operation
- Hard lacquered steel frame, heat insulated
- Power supply: Battery life approx. 2 years

Functions:

AUTO-ON/OFF, RESET (set display to zero), mm/inch, HOLD, (storage of measured values), LOCK function (key lock)

Micromar 40 ER / 40 EWR Digital Micrometers

40 EWR protection against dust & coolants.

Product	Measuring range		Resolution	Order No.
	mm	(inch)		
40 ER	0-25	(0-1")	0.001/0.00005	4157010
40 EWR	0 - 25	(0 - 1")	0.001/0.00005	4157011
40 EWR	25 - 50	(1 - 2")	0.001/0.00005	4157012
40 EWR	50 - 75	(2 - 3")	0.001/0.00005	4157013
40 EWR	75 - 100	(3 - 4")	0.001/0.00005	4157014

Micromar 40 EWRi Digital Micrometers

Digital micrometers with Integrated Wireless

Product	Measuring range		Resolution	Order No.
	mm	(inch)		
40 EWRi	0 - 25	(0 - 1")	0.001/0.00005	4157100
40 EWRi	25 - 50	(1 - 2")	0.001/0.00005	4157101
40 EWRi	50 - 75	(2 - 3")	0.001/0.00005	4157102
40 EWRi	75 - 100	(3 - 4")	0.001/0.00005	4157103

Micromar 40 EWRi-L Digital Micrometers

Digital micrometers with Integrated Wireless and QUICK DRIVE quick adjustment

Product	Measuring range		Resolution	Order No.
	mm	(inch)		
40 EWRi-L	0 - 25	(0 - 1")	0.001/0.00005	4157120
40 EWRi-L	25 - 50	(1 - 2")	0.001/0.00005	4157121
40 EWRi-L	50 - 75	(2 - 3")	0.001/0.00005	4157122
40 EWRi-L	75 - 100	(3 - 4")	0.001/0.00005	4157123



- For Wireless Data Transmission
 - Industry 4.0 Compatible
 - Software Marcom professional
- Free Download : www.mahr.com



i-stick
order no 4102220

Micromar | 44 EWR(i)



Digital 3-point inside micrometer with unique compact measuring element

The Micromar 44 EWR(i) digital 3-point inside micrometer for measuring inner diameters boasts a lighter and more compact measuring element than its predecessors – for even more sensitivity and clarity when measuring.



Compact plastic measuring element

Wear- and corrosion-resistant measuring heads

Tried and tested function keys

Large screen with integrated tolerance display

Outstanding connectivity and remote control capability

Smooth ratchet stop

Advantages

- Lightweight and compact plastic micrometer unit
- Corrosion- and wear-resistant measuring heads
- Wide range of sizes for measuring ranges from 6 to 200 mm
- Preset: 3 PRESET and tolerance values possible
- Connectivity: Model available both as 44 EWR with bidirectional data output (cable) or 44 EWRi with Integrated Wireless
- Download free MarCom Professional software
- Available as an individual instrument or as a set



S.No.	Order No.	Description
1	4191240	44 EWR Dig. Inside Micrometers 6 - 12 mm , in Set
2	4191241	44 EWR Dig. Inside Micrometers 12 - 20 mm , in Set
3	4191242	44 EWR Dig. Inside Micrometers 20 - 50 mm , in Set
4	4191243	44 EWR Dig. Inside Micrometers 50 - 100 mm , in Set
Ranges available upto 200mm		





Digital 3-point inside measuring device **with lever retraction**

The Micromar 844 EWR(i) digital 3-point inside measuring device for measuring inner diameters boasts an ergonomic handle with release lever for fast, self-centering measurements over the entire measuring range and a rotating display with touch operation.

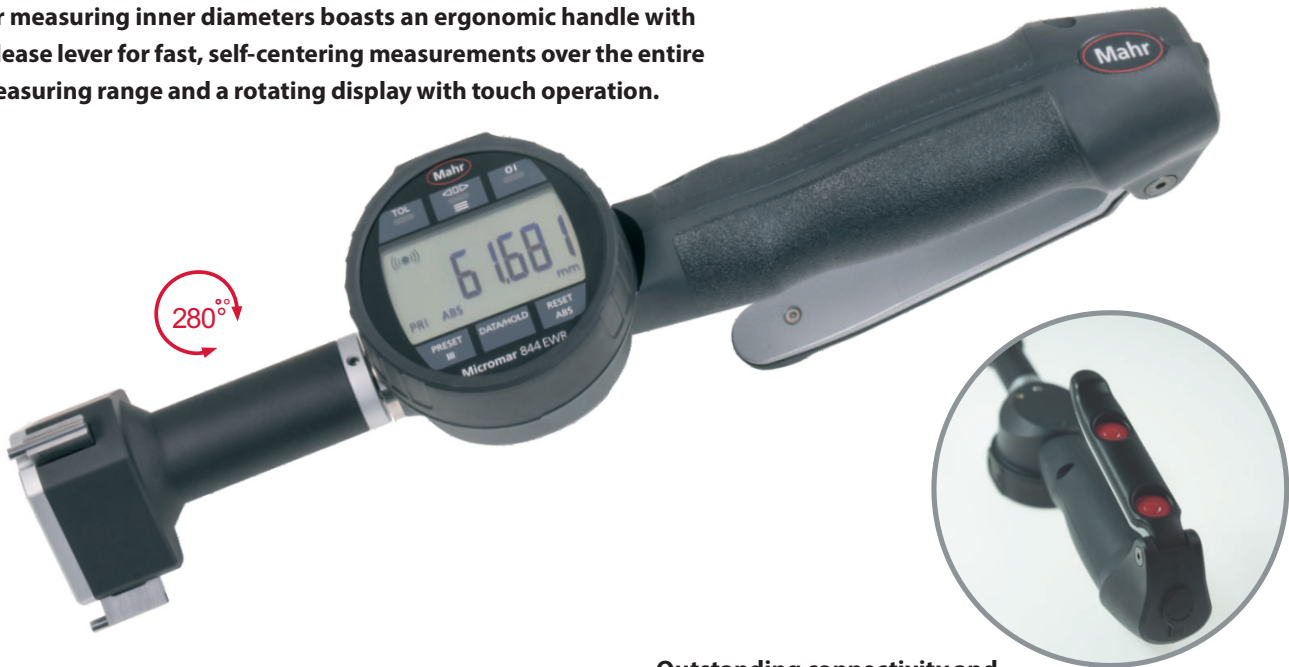

Advantages

- Measuring pistol with lever retraction for fast and self-centering measurement of different diameters
- Integrated measuring system with conveniently rotating display module
- Wide range of sizes for measuring ranges from 6 to 100 mm
- Preset: 3 PRESET and tolerance values possible
- Connectivity: Model available both as 44 EWR with bidirectional data output (cable) or 44 EWRi with Integrated Wireless
- Remote control via the free downloadable MarCom Professional software
- Available as an individual instrument or as a set

Outstanding connectivity and remote control capability

Ergonomic handle with lever retraction

Handy DATA/HOLD keys in the lever

Rotating screen with touch operation and integrated tolerance display

Wear- and corrosion-resistant measuring heads



S.No.	Order No.	Description
1	4192340	844 EWRi Dig Inside Meas-Gages 6 - 12 mm , in Set
2	4192341	844 EWRi Dig Inside Meas-Gages 12 - 20 mm , in Set
3	4192342	844 EWRi Dig Inside Meas-Gages 20 - 50 mm , in Set
4	4192343	844 EWRi Dig Inside Meas-Gages 50 - 100 mm , in Set
Ranges available upto 200mm		

MarTest | Highly Sensitive Measurement

Since 1936 Mahr has been one of the world's leading suppliers of dial test indicator measuring devices. The sensitive computer-optimized mechanism ensures maximum security and precision. MarTest instruments are ideal for use in workshop conditions, with sealed dials ensuring liquid resistance.



- High contrast dial face, sealed with an O-ring
- Satin chrome-finished housing with 3 dovetail guideways
- Shockproof mechanism
- Anti-magnetic
- Ball-bearing mounted double lever, friction clutch for overload protection
- Measuring anvil with carbide ball $\varnothing 2$ mm
- Hardened mineral glass viewing panel, resistant to breakage and scratching

MarTest 800 S / SGE / SGM

Dial test indicator

Product	Measuring range	Resolution	Dial Diameter	Measuring anvil length	Order No.
	mm	mm	mm	mm	
800 S	± 0.4	0.01	28	14.5	4305200
800 SGE	± 0.7	0.001	38	9.15	4308220
800 SGM	± 0.1	0.002	38	14.5	4308200

Marcator | Points you in the Right Direction

Due to their versatility, dial indicators rank as some of the most commonly used transducers. That is certainly the case with our MarCator series. Our mechanical dial indicators have precision gears and pinions for maximum accuracy. Also available in shock proof and water proof versions

- High contrast dial face
- Adjustable colored tolerance markers for optimum contrast
- Chrome-plated metal housing
- Lifter protection cap with dust protection function
- High-precision gears and pinions



MarCator - 810 A /SRM Precision Dial Indicator

The classic indicator with a lifter protection cap

Product	Measuring range	Resolution	Dial Diameter	Details	Order No.
	mm	mm	mm	Measuring Force	
810 A	10	0.01	50	0.7-1.3 N	4311050
810 SRM	5	0.001	50	1.2 - 1.7 N	4311080
810 SRM	1	0.001	50	1.3 - 1.8 N	4311070

MarCator | Digital Measurement

Our innovative range of digital dial indicators includes high-precision electronic measuring systems, allowing for a whole range of additional practical measuring functions. Simple to operate with a large, easy-to-read display, our digital dial indicators meet all the requirements of a modern measuring instrument. Quick and easy data processing ensures results are available when you need them.

- High contrast LCD
- Protection cap on end of measuring pin
- Power supply: Battery life approx. 3 years

Functions: ON/OFF, RESET (set display to zero), mm/inch, reversal of counting direction, PRESET (enter a numerical value), DATA (data transmission via connection cable), LOCK function(key lock), AUTO-ON/OFF

MarCator 1075R | With large display

Product	Measuring Range		Resolution	Order No.	Features
	mm	(inch)	mm / inch		
1075R	12.5	0.5	0.001 / 0.00005"	4336030	Preset
1075R	12.5	0.5	0.01 / 0.0005"	4336010	Preset
1075R	12.5	0.5	0.005 / 0.0001"	4336020	Preset



MarCator 1086 R(i) / 1087 R(i)

Digital dial indicators with unique connectivity

The latest generation of digital dial indicators in the MarCator family boasts new, innovative features: Touch operating keys, extra hardened glass fronts, colored LEDs for measurement classification and unrivalled remote control and connectivity ensure unique convenience when measuring and setting the device.

Precision Redefined:

- **Touch Operation:** Gentle touch keys for safe, sensitive measurements.
- **Clear Display:** Hardened glass front with large, readable digits.
- **Smart Classification:** Colored LEDs instantly flag good, waste, or warning limits.
- **Versatile Use:** Ideal for static (lengths, distances) and dynamic (runout, flatness) tasks, with 1087 BR(i) for inner/outer measurements.
- **Best-in-Class IP Protection:** Special versions offer enhanced durability.
- **Connectivity:** Wireless (Ri) or USB data transfer, plus remote control with free MarCom software.



available in 1087 R(i)

TECHNICAL DATA

TYPE	1086 R				1086 Ri		1087 Ri	
	Order No.	4337701	4337702	4337703	4337720	4337721	4337820	4337821
Range (mm)	12.5	25	50	100	12.5	25	12.5	25
Resolution (mm)	0.01 0.0005, 0.001, 0.002, 0.005, 0.01				0.0005, 0.001, 0.002, 0.005, 0.01		0.0005, 0.001, 0.002, 0.005, 0.01	
Error Limit (mm)	0.004		0.007		0.004		0.004	
Connectivity	USB, Digimatic				Integrated Wireless, USB, Digimatic, Opto RS-232C			

Millimes | 2000W (i) / 2001W (i)

Inductive Comparator

Millimes Digital Comparators are NOT Indicators !!

A digital dial comparator – highest level of precision thanks to inductive measuring system

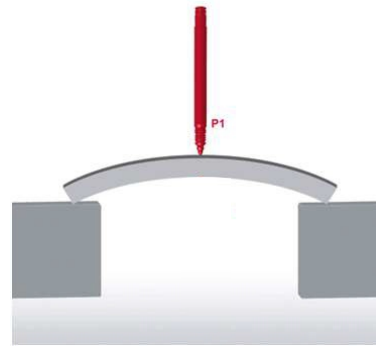

- Tempered glass front with touch control panels
- High-contrast LCD display
- Clear tolerance symbols and colored LED signals (red, green, yellow) for measured value classification
- with warning limit input: No Go / Go / Warning Limit
- without warning limit input: No Go / Go / Rework

High precision inductive measuring system

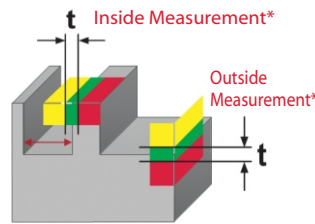
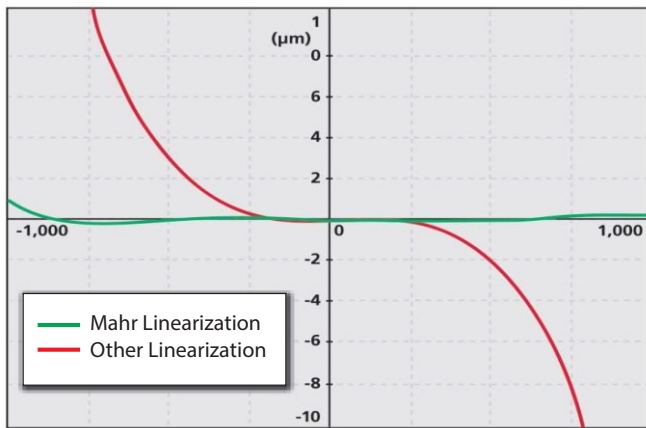

Convenient tolerance functions



Order No.	4346700	4346701	4346800	4346801
Type	2000 W	2000 Wi	2001 W	2001 Wi
Measuring range	mm	± 1		
Resolution	mm	0.0001, 0.0002, 0.0005, 0.001, 0.002, 0.005, 0.01		
Resolution	inch	.000005", .00001", .00002", .00005", .0001", .0002", .0005"		
Error limit	µm	± (0.2 + 0.5 x L) L in mm		
Measuring value hysteresis fu	µm	0.3		
Repeatability fw	µm	0.1		
Measuring force	N	0.9 ± 0.1 (Reference to absolute zero point of inductive measuring system)		
Range of analog display	mm	± 0.002, ± 0.004, ± 0.01, ± 0.02, ± 0.04, ± 0.1, ± 0.2		
IP protection category		IP 64		
Supply voltage		100– 240 V		

Millimes | Points you In the Right Direction

Precision probe made in 1937. It was the first indicating instrument for the reliable determination of dimensional differences with 1/1000 mm



- Large, high contrast dial face
- Adjustable tolerance markers
- Lockable fine adjustment screw
- Shock proof movement
- Mounting shank and measuring spindle are both made of hardened stainless steel
- Measuring spindle is mounted in a high precision ball guide for minimal hysteresis
- Resistant to lateral forces (sideplay) acting on the measuring spindle
- Maximum sensitivity and accuracy are ensured by the jeweled movement in conjunction with the precision gears and pinions.

Product	Measuring Range	Resolution	Order No.	Mounting Shaft
1010	± 0.250mm	0.01mm	4332000	Ø8h6
1003	± 0.050mm	0.001mm	4334000	Ø8h6
1002	± 0.025mm	0.0005mm	4335000	Ø8h6
1000A	± 0.120mm	0.001mm	4338100	Ø28h6, Ø16h6

Multimar | Universal Measuring Instruments 844 T

Whether you are measuring gears, threads, cones or grooves, Multimar universal measuring instruments are an ideal solution for almost all internal and external measurements for which standard measuring instruments are unsuitable. A choice of basic units and an extensive range of accessories are available.

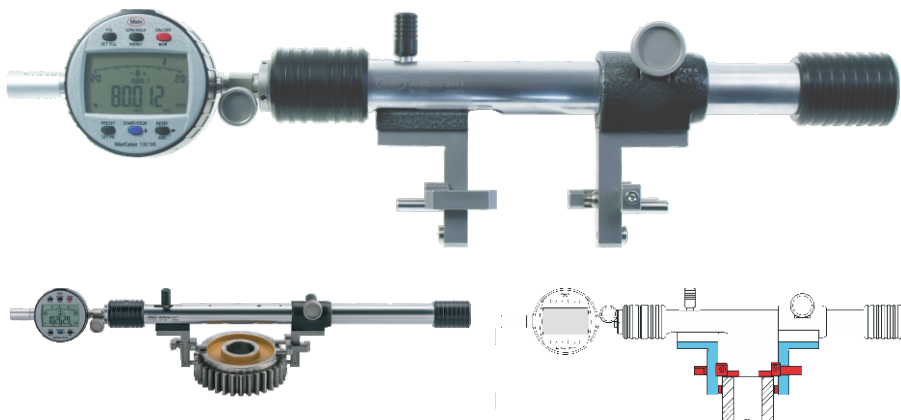

Accessories

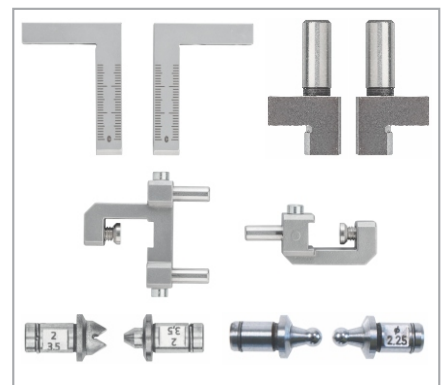

Order No.	Product Type	Application range outside	Application range inside	Measuring Force	Travel of movable anvil	Product weight
		mm	mm	N	mm	kg
4503001	844T	0 - 85	30 - 115	5	12	0.78
4503002	844T	80 - 235	110 - 265	5	12	1.01
4503003	844T	230 - 585	260 - 615	5	12	1.59

upto 4500mm range is available.

Marameter 852 & 853 | Indicating Thread Snap Gages

Marameter - Indicating measuring instruments

Marameter is the ideal instrument series for high-precision measurements of inside and outside diameters on individual and serial parts. These indicating measuring instruments obtain the best results due to their constant measuring force, accurate transmission mechanisms and the high parallelism of their measuring surfaces. Marameter also offers compelling solutions for special measuring tasks.

Indicating Thread Snap Gage 852

For pitch, root and outside diameters of all kinds of external threads and serrations

Features:

- Rugged, forged steel frame with heat insulators
- Measuring spindle mounted in long guideway with lever-controlled retraction
- Anvil spindle easily fine-adjusted
- Both spindles made of hardened stainless steel with mounting bore for interchangeable anvils
- Adjustable center stop for automatic alignment
- Constant measuring force via built-in spring – eliminates user influence



Depending on anvils used (ordered separately)
Excludes indicating instrument and anvils

Technical Data

Order No.		4510000	4510001	4510002	4510003
Type		852			
Application range	mm	0-45	45-85	85-140	140-190
Measuring span	mm	2		2.5	
Repeatability fw	µm	1			
Measuring Force	N	7.5		9	

Indicating Thread Snap Gage 853

Dedicated version for taps – pitch, root and outside diameters

Features:

(identical rugged base design as 852 plus tap-specific advantages)

- Anvil spindle adjustable via worm and rack for mounting interchangeable support yokes
- Support yokes available for 3, 5 and 7-flute taps
- Compensation factor table supplied for multi-flute taps

Cat. no.	Flutes	Range mm	Factor	Order no.
853 qk 3	3	1.2–35	×1	4511024
853 qk 5	5	1.2–35	×1.34	4511026
853 qk 7	7	1.2–35	×1.42	4511028
853 qg 3	3	35–75	×1	4511025
853 qg 5	5	35–75	×1.34	4511027
853 qg 7	7	35–75	×1.42	4511029

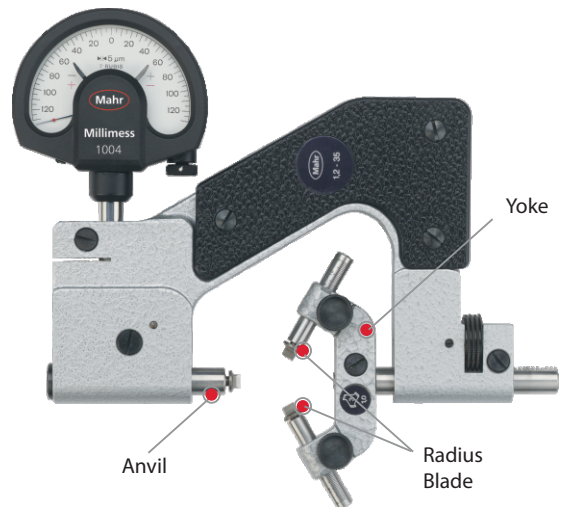

Excludes indicating instrument and support
Interchangeable Support Yokes 853 q*
(compensation factor must be applied)

Technical Data

Application range mm (inch)	Repeatability fw µm	Measuring force N	Order no.	Measuring Span
1.2 - 35 (.04 – 1.37")	2	7.5	4511000	8 mm
35 - 75 (1.37– 3")	2	7.5	4511001	8 mm

Interchangeable Anvils for 852 and 853

For pitch, root and outside diameter. Special wear-resistant hardened steel. With cylindrical mounting shank and retainer ring which ensures locking while permitting rotation in bore of indicating snap gages.

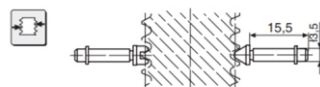

Sets consist of:

For pitch diameters
852 - 1 V-anvil and 1 blade
853 - 1 V-anvil and 2 radiused

For root diameters
852 - 1 V-anvil and 1 blade
853 - 1 V-anvil and 2 blades

For outside diameters
852 - 2 flat-face anvils
853 - 3 flat-face anvils

Advantages at a Glance

- Go/No-Go with data inspection in seconds
- Constant measuring force – no operator influence
- Interchangeable anvils for virtually all thread types
- Ball Anvils & Roller Blades also available for gear and special applications

Marameter | 844 D - The Smart Drop-In Replacement for Air Gaging

Precision internal measurement without air. No compressed air, no nozzles, no maintenance, no temperature drift – just pure mechanical ± 2 -point contact and 0.0001 mm repeatability.

Why 844 D beats air gaging every time ?

- Zero operating cost – no air supply, filters, regulators or dryer needed
- Massive savings – eliminates 100% of air consumption and servicing costs
- Rock-solid accuracy – immune to oil, dust, coolant mist and temperature swings
- True reversal point – self-centering 2-point guide cylinder finds the real bore center (air can't)
- Instant setup – set with one ring gauge, no master rings + plugs combo required
- Wear-free transmission – inductive system, no air nozzle clogging or erosion
- 0.15 – 0.60 mm measuring span – covers almost all common bore tolerances in one plug
- Ranges 2–200 mm – standard, blind or through-bore versions

Three versions – same cost-saving performance

- 844 D Standard bore
- 844 DS Blind bore / shoulder stop
- 844 DR Through bore

3 Basic types

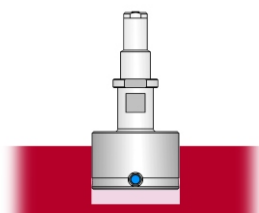

844 D Standard Bore

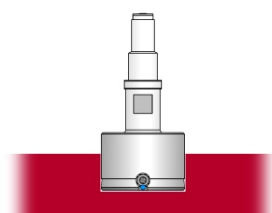

844 DS Blind Bore

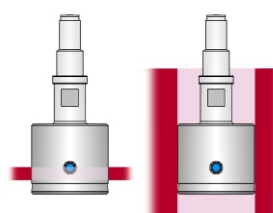

844 DR through Bore



Drop the air line. Plug in a Marameter 844 D. Cut your bore gauging cost by 70–90 % from day one – while gaining higher accuracy and zero downtime.

Marameter | 844 K - Self-centering inner measuring device

High-precision comparative measurements of holes

Inside measuring probes from the 844 K family are 2-point comparative measuring instruments used to determine a reversing point in a bore by oscillation. This reversal point equates to the minimum and thus the exact bore diameter.

Features :

- Small inner diameter starts from 0.95mm
- For indicating measurement of diameter and testing for roundness and conicity of bores
- Repeatability within 1 μ m



Standard Holes



Standard Holes
with DLC coating



Blind Holes



Millimar | C1202

The new Millimar C 1202 compact instrument is versatile and suitable for use with a variety of sensors.



Three features can be displayed at the same time - for even more static and dynamic measuring tasks

- Two independent inputs via N 1700 module for the optional connection of measuring probes and pneumatic transducers
- Interchangeable modules for flexibility and compatibility
- Digimatic and USB ports for easy connection to data collection systems and evaluation software
- Programmable measuring sequences for greater productivity and reliability

Probe input	DRO	Resolution	Range	order no	Description
Single VLDT	C1200	0.1µm	±5mm	5312012	Features varies from C1202
Duel VLDT	C1202	0.1µm	±5mm	5312025 plus 5331120	N 1702 M
Duel Channels	C1202	0.01µm	±0.2mm	5312025 plus 5331125	N 1702 M - HR
Four Channels	C1202	0.1µm	±5mm	5312025 plus 5331140	N 1704 M
Air Gaging	C1202	2500/5000		5312025 plus 5331155	N 1702 M
Air Gaging	C1202	10000		5312025 plus 5331157	N 1702 M
Incremental Probe	C1202	0.1µm		5312025 plus 5331134	N 1704 I/O



N1701



N1702



N1704



N1704 I/O



C1200

Millimar | Inductive & Incremental Probe

- Wide product spectrum measuring ranges from 1 to 30 mm plus models with a compressed air (pneumatic) lifter or vacuum retraction.
- With rotary stroke bearings (except P2001)
- High linearity over the total measuring range VLDT - Full Bridge
- Excellent electromagnetic shielding (EMC)
- All probes (except P2001) can be easily converted from axial to radial by mounting a slip-on cap, included in the scope of supply



Model : P2004
Order No.: 5323010



Model : 1301
Order No.: 5313010



Model : P1230 V
Order No.: 5315311

Probe	Order no	Range	Repeatability fw	Type
1301	5313010	±1mm	0.0001mm	VLDT - Full Bridge
1303	5313030	±1mm		
P2004M	5323010	±2mm		
1340	5313400	±2mm	0.00008mm	
P1512 V	5315081	12mm	1µm	DIADUR-glass scale with incrementa
P1530 V	5315311	30mm	Sys. Accuracy	

Millimar | A 1701 M

Analog Signal Converter for Automation



Compact PLC interface module that converts length signals from Mahr inductive probes (and any Mahr VLDT probe) into **standard analog ±10 V or 0–10 V output**. Perfect for direct integration into production lines and automated inspection systems.

Advantages :

- One input for any inductive probe (LVDT standard compatible)
- Real-time, drift-free signal processing
- Adjustable zero & gain via front potentiometers
- Includes manual 4-pin M9 male connector for easy calibration
- Dual analog outputs in one ultra-compact, rail-mount housing
- Fast and error-free data transmission
- IP 42 protection, 12–30 V DC powered

Application :

Directly feeds high-precision measurement values from the probe into PLCs, controllers, or process control systems – no display, just pure analog performance.



One module.
Any probe.
Straight to your PLC

TECHNICAL DATA

Order No.	5331135		
Type	A 1701 M		
Measuring range, inductive probe	µm	± 50, ± 100, ± 200, ± 500, ± 1000, ± 2000	
Error limit, analog output	0.2 µm and 0.3 % resp. (the larger value applies)		
Display	No display, amplifier with analog output		
Features	1		
Energy supply:	12 ... 30 V, DC		
Current consumption	mA	150 max	
Probe inputs	1		
Compatibility	Mahr		
Data interface:	analog, ± 10 V, 0 – 10 V		
Analog output	Voltage output at end of range: • ± 10 V • 0– 10 V		

Millimar Cockpit 14 | Measuring Software

Smart, optimized software that turns complex measurements into fast, error-free results.



Core Features & Benefits :

- Clean, fully interactive touch interface
- Instant task setup with intuitive workflow
- Preloaded formulas for all standard features
- Static & dynamic measurement modes
- Live graphical + analog displays (up to 128 features at once)
- Direct plug-and-play with Millimar N 1700 modules & inductive probes
- Full support for Mahr wireless instruments and cabled devices
- Attach photos/drawings to each measuring task
- History Module – complete measurement traceability
- Temperature Compensation Option – automatic accuracy correction
- Export to Excel or qv-Stat (.dfq, .dfx, .dfd)

Order No.	Description
5312865	Millimar Cockpit Software MarWin 14
5312862	History Module
5312866	Temperature Compensation Option
5312871	Millimar C 1751 PC (incl. Cockpit)
5312950	Extension Rail for C 1202

Complex metrology. Simple workflow. Total control.

MarConnect I MarCom Prof. 5.5

Directly transfer measured values into MS Excel®, SPC Software using virtual interface box (MUX50 format), a text file or key code

- The measured values for each connected measuring instrument can be copied into a separate column, table or folder in MS Excel®
- USB hubs can also be connected as a measuring instrument interface
- Clear depiction of the selected measuring devices by means of icons
- Freely definable and configurable transmission via the "Data" button on the measuring device or data cable or via a PC keyboard, timer, remote control or foot switch connected to a USB interface

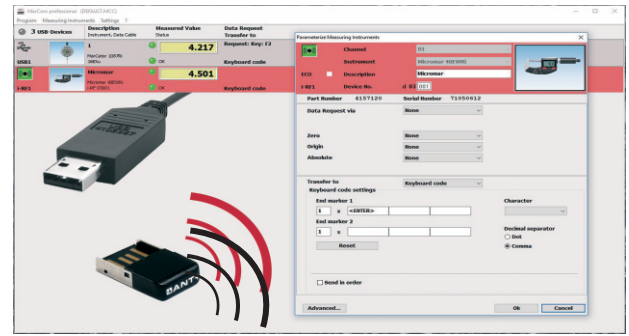

TECHNICAL DATA

Product Type	Marcom Prof 5.3
Number of connectable wireless receivers for i-stick	4
Number of connectable measuring instruments with integrated wireless	32
Number of connectable wireless receivers for e-Stick	1
Number of connectable transmission modules for e-stick	8

MarConnect I MarCom App MarCom App for Tablets with Android OS



Maximum mobility due to Wireless-System by MAHR
The Mahr Wireless series provides a modern and easy way to measure - without the restrictions of wired technology.
Previously, only the measuring devices were without a cable connection, but with the new MarCom App, the data receiving station is also wireless.

- Easy connection of up to 8 i-Wireless measuring instrument
- Clear display of the selected measuring devices via icons
- Graphic display of measured values as actual values
- User administration with password
- The measured values can be exported as an xlsx or pdf file

NEW: MarCom APP
Tablet with Android v.10 or higher
8 i-Wireless measuring devices

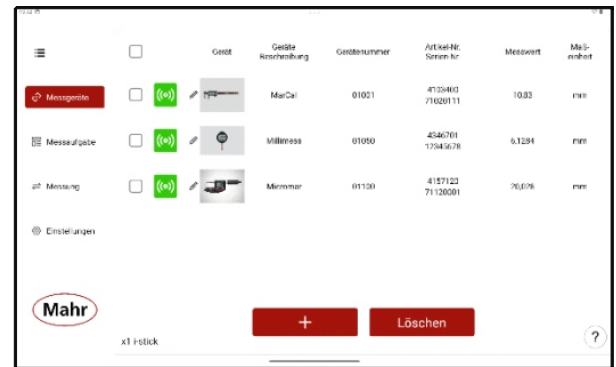

MarCom App

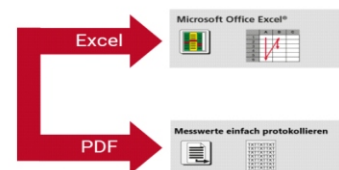

Millimar Air Gaging

Innovative products and solutions

Though most frequently used for diameter measurement, many other types of dimensional conditions can be checked more conveniently, more accurately, and more economically with the Dimensionair than with other types of gages. Though it would be impossible to show every type of measurement successfully accomplished by air, here are a few representative examples.



Apart from basic Inner and outer diameter measurements, Configurations for air gaging...

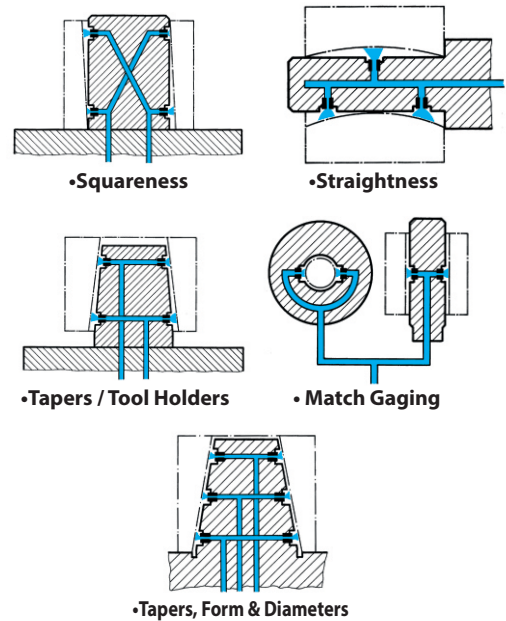

Know your Air Tools for Gaging system :

- 1 Part dimension with Tolerances
- 2 Keep surface finish Ra < 2.5% of the total part tolerance
- 3 Display Type - DRO/ Cockpit Software upto 128 features
- 4 Resolution & Range of the System

Range of taper gage applications



The Millimar C 1202 differential system with taper machine tool holders and spindles

The use of tapers has never been more important than it is today. In the manufacture of tool holders and spindles, the control of taper and size determines how well the machine can perform during its cutting cycle. In orthopedic parts, the matching of tapers is critical to how well the knee or shoulder replacement will perform. Air gaging is ideal for these applications. Multiple circuit air jets can be placed in very small tapers where no other method can be used to match air gaging speed and performance. Two conditions most important in controlling taper are taper size and angle. Size is controlled by tolerance and is, therefore, identical to a cylindrical ID or OD taper angle, on the other hand, can be controlled by at least three different methods:

1. Included angle or angle per side.
2. Taper per inch or per foot.
3. Controlling two diameters at specified datum locations.

When specifying a taper requirement, always consider:

- What is to be measured?
- Taper angle
- Diameters at certain locations
- Taper and diameter
- Length of taper and possible location for sensing points
- Should the gage be portable or bench mounted ?
- What does the operator need for readout ?

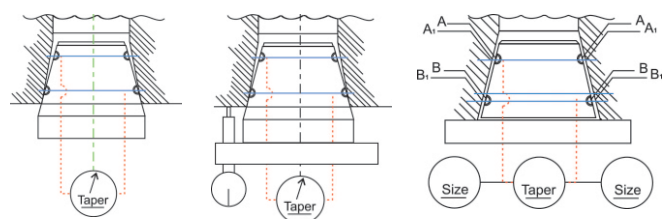

MarSurf | Surface Roughness Instruments

The best of the mobile devices

Mahr's entry-level surface metrology instrument is intuitive and simple to use.

Careful testing is paramount wherever surface structures affect the function or appearance of components. MarSurf surface measuring instruments offer outstanding quality. Mahr has perfected the stylus method, which has now become established worldwide. But we can also meet the latest demands for contactless measuring with a range of optical sensors. Mahr's MarSurf surface metrology offers a combination of top quality, maximum competence and perfect expertise.

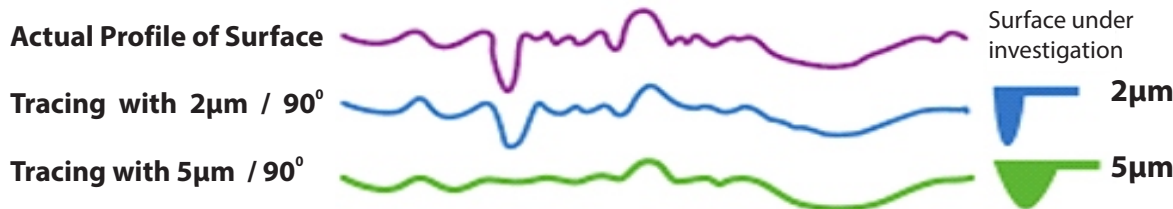

Choice of Wavelength				
EN ISO 4288, ASME B46.1				
Periodic profiils	Non periodic profiils	Cut off wave-length	Single/ Total measuring range	
R_{sm} (mm)	R_z (µm)	R_a (µm)	λ_c (mm)	I_r / I_n (mm)
> 0,013 to 0,04	to 0,1	to 0,02	0,08	0,08 / 0,4
> 0,04 to 0,13	> 0,1 to 0,5	> 0,02 to 0,1	0,25	0,25 / 1,25
> 0,13 to 0,4	> 0,5 to 10	> 0,1 to 2	0,8	0,8 / 4
> 0,4 to 1,3	> 10 to 50	> 2 to 10	2,5	2,5 / 12,5
> 1,3 to 4	> 50 to 200	> 10 to 80	8	8 / 40

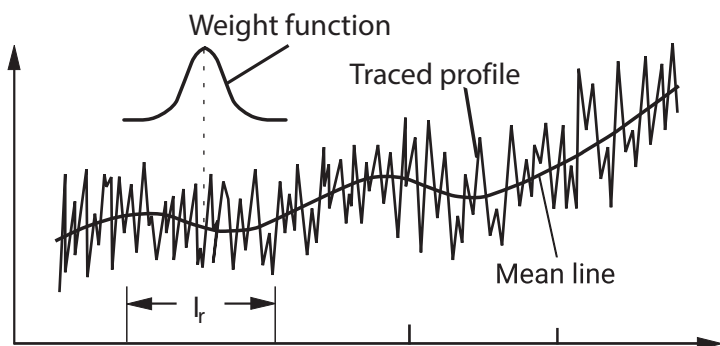

MarSurf PS10 | Mobile Surface Metrology — Smart, Flexible, and Precise

The New Standard in Portable Surface Measurement

The **MarSurf PS10** from Mahr redefine mobility in surface roughness measurement.

Designed for shopfloor and quality lab use, with laboratory-grade precision with intuitive operation and complete measurement freedom - directly where production happens.

Engineered for simplicity, combines 31 roughness parameters, automatic cutoff, and PDF generation into a single, intuitive instrument.



Highlights — PS10

- Built-in vibration check (Drive-Off function) for shop floor reliability
- All-in-one compact system
Drive, pickup, and evaluation in a single housing with integrated height adjustment.
- Removable drive unit for flexibility on large or complex parts.
- Integrated calibration standard for traceable accuracy anywhere.
- Battery-powered mobility — over 1,200 measurements per charge.
- Quick PDF reporting directly on the device — no external software required.
Extended Memory: Store 500,000 results & 1,500 PDF reports.
- Standards-compliant (ISO, DIN, ASME, JIS) stylus measurement.
- Annual firmware updates for continued performance improvements
- Optional MarConnect interface for data transfer to PC
- Optional microSD card (up to 32 GB) for extended data storage
- Tolerance Monitoring: Set parameter limits with pass/fail indication.

Mahr		Fa. Steinhilber GmbH		MarSurf PS 10	
Prüfer M. Adler		Zeilhung Nr.: 7 10 25 10 42 16		1.00.14	
Erstellungsdatum:	18.10.2016 08:34	Lt:	4,8 mm		
Gerät:	MarSurf PS 10 (1918)	Lt:	2,5 µm		
Tester:	MHR 200	W:	+/- 200,0 µm		
		V:	1,0 mm/s		
		Prüfzeit:	9600		
Serie 90		Fläche an Bohrung Nr.:			
Serie 4419		Fertigungsplatz 26			
Auftrag Nr. 13					
Vor: 10,0 µm/Std; Hor: 0,8 mm/Std;					
Pa	3,455 µm	0,000			3,000
Rq	4,555 µm	0,000			6,000
Rd	19,811 µm	20,000			25,000
Rz	19,811 µm	0,000			10,000
Rt	11,870 µm	11,000			20,000
Rmax	29,156 µm	0,000			25,000
Rp	2,554 µm	0,000			10,000
Rq(ASME)	11,414 µm	0,000			12,000
Rpm	2,554 µm	0,000			8,000
Rv	12,357 µm	0,000			12,000
Rt	29,156 µm	22,000			25,000
RIR (0,50 - 0,50)	118 %	0,00			125
RIR (1,00 - 5,0)	2,90 %	0,00			10,00
RIR (2,00 - 5,0)	12,25 %	0,00			15,00
RIR (3,00 - 5,0)	19,77 %	0,00			20,00
tp (1,00 - 5,0)	2,90 %	0,00			10,00
tp (2,00 - 5,0)	12,25 %	0,00			12,00
tp (3,00 - 5,0)	19,77 %	0,00			15,00
RSm	62,419 µm	0,000			125,000
RtS	62,963 µm	0,000			10,000

MarSurf M310 | Smart. Connected. Traceable

The New Standard in Portable Surface Measurement

The MarSurf M310 builds on PS10's simplicity with a powerful feature set for advanced users, integrating traceability, connectivity, and automation for industries that demand more - especially automotive and precision manufacturing.



Added Features & Upgrades except Features of PS 10 :

- IATF 16949 Ready: Traceability through gauge ID with every measurement.
- Wireless Printer Support: Instant printing of profiles, MRC & ADC curves.
- MarWin Easy Roughness (PC): Advanced analysis, extended parameters & SPC control.
- QR / Barcode Scanning: Quick program selection & automated job assignment.
- Remote Control Interface (ASCII): Integration with automation or external software.
- Transverse Tracing Sets: RD18 C2 for crankshaft/camshaft measurement. With MarSurf PS10 C2 / M310 C2 Set

MarSurf PS10 & M310 – Precision Meets Portability

- Fast. Flexible. Reliable
- Traceable, compliant, and future-ready
- Made by Mahr - engineered for confidence in every measurement

Order no.	6910230	6920235	6910260	6910264
Feature	MarSurf PS10	MarSurf PS10 C2	MarSurf M310	MarSurf M310 C2
Display	4.3" TFT touch (scratch-resistant)			
Operation	Basic, smartphone-like		Advanced, programmable keys	
Traversing length acc. to ISO 12085 MOTIF (in mm)	1, 2, 4, 8, 12, 16	1, 2, 4	1, 2, 4, 8, 12, 16	1, 2, 4
Evaluation length in mm acc. to ISO/JIS	1.25, 4, 12.5	1.25, 4	1.25, 4, 12.5	1.25, 4
Skid Measurements	2µm/90° with 45° Approach Angle			
Measuring Range/ Resolutions	350µm/8nm			
Drive Type	Straight	Transverse	Straight	Transverse
Connectivity	microUSB, microSD, MarConnect Duplex		USB-A, microUSB, Wireless, MarConnect Duplex	
Data Storage	500,000 results + 1,500 PDFs			

Pocket Surf® IV | The Portable Surface Roughness Gage

The Pocket Surf IV is simple to use and easy to read, displaying measurement results of Ra, Rz, or Rmax at a glance. This portable surface finish gage employs Mahr's unique MarConnect universal interface which allows for USB, RS-232 or digimatic output of data by choosing the right cable.



Order No.	2191800	2191802
Traverse Length (Nominal)	R _a /R _y	2.0mm / 0.075 in 3.5 mm / 0.135 in
	R _v /R _z /R _{max}	5.0 mm / 0.195 in
Evaluation Length	R _a /R _y	0.8mm / 0.030 in 2.4mm / 0.090 in
	R _v /R _z /R _{max}	5.0 mm / 0.150 in
Includes	10 µm Radius	5 µm Radius, Certified Specimen, Probe

Note: A Pocket Surf kit includes a Pocket Surf unit, general purpose probe, 3,2 µm/125 µin (nominal) reference specimen, 9 Volt battery, riser plate, and a fitted case

MarSurf M 410 | CNC Surface Roughness Measurement System

Precision Meets Productivity

The MarSurf M 410 combines high-accuracy tactile surface measurement with the efficiency of automation — delivering faster results, higher repeatability, and lower cost of ownership.

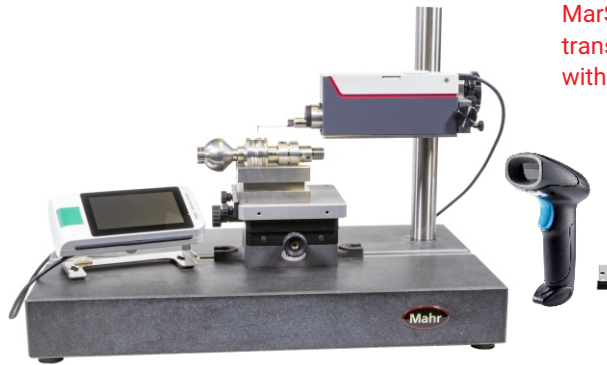
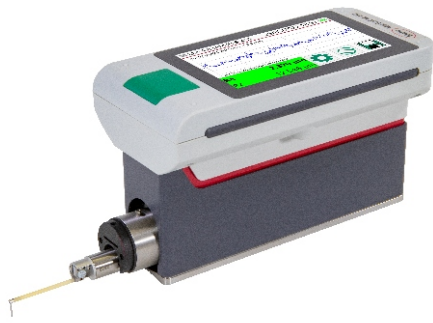

MarSurf M 410 allows the transmission of a gauge ID with each measurement

IATF 16949



Features:

CNC-Controlled Measurement

- Fully automated probe positioning and contact with the surface.
- Ensures repeatability and eliminates operator influence.
- Ideal for high-precision, multi-part, or multi-feature measurements.

Magnetic Probe Mounting System

- Quick, tool-free probe changes in seconds.
- Automatic calibration data recall via MarWin software.
- Built-in collision protection prevents probe damage - zero downtime, maintenance-free operation.

PC-Based System Integration (Optional)

- Seamless connectivity with MarWin software for advanced analysis.
- Enables digital data management, traceability, and Industry 4.0 compatibility.

Smart ROI Advantage

- Faster Throughput: CNC automation reduces cycle time.
- Lower Maintenance: Magnetic design avoids probe breakage.
- Higher Consistency: Repeatable results ensure better process control and fewer reworks.

Versatile & Future-Ready

- Modular configuration for lab or production use.
- Compatible with a wide range of probes and accessories.
- Scalable for advanced automation or multi-axis setups.

High-precision stylus measurements of roughness, waviness and primary parameters

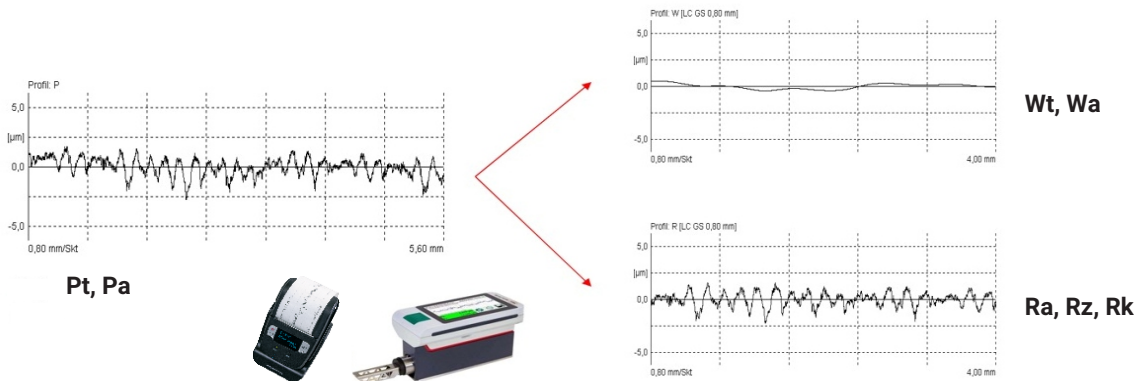

Wt Total Height of W-Profile

- DIN EN ISO 21920, ASME B46.1 - W-profile: Mean line from P-profile (S-filter nests index $\lambda(N_c)$, cut-off $\lambda(\lambda_{c_c})$).
- Excludes large-scale form components.
- **Wt** = Sum of largest peak height + largest pit depth within evaluation length (L_e) .

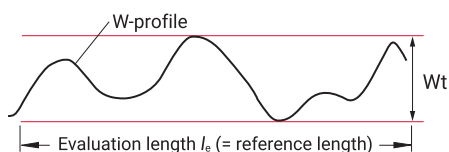

WDSm, WDC, WDt – Dominant Waviness

VDA 2007

The evaluation method identifies periodically dominant characteristics; parameters are derived from this special waviness profile (WDprofile).

WDSm: Mean horizontal size of profile elements (mean period of dominant waviness).

WDC: Mean height of profile elements within evaluation length.

WDt: Vertical difference between highest and lowest point of WD-profile within (L_e) .

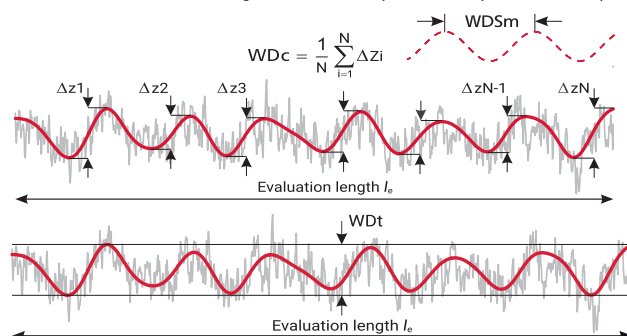

MarSurf MD 26 CNC | Powered by MarWin Easy Roughness

Compact Precision Meets Simplicity

The MarSurf MD26 delivers CNC-based precision and automation in surface roughness measurement — combining the reliability of high-end systems with outstanding affordability. Designed for customers who demand accuracy, repeatability, and efficiency, the MD26 brings true system-level capability without the heavy investment of larger platforms.



Determine a simple contour in addition to a roughness measurement

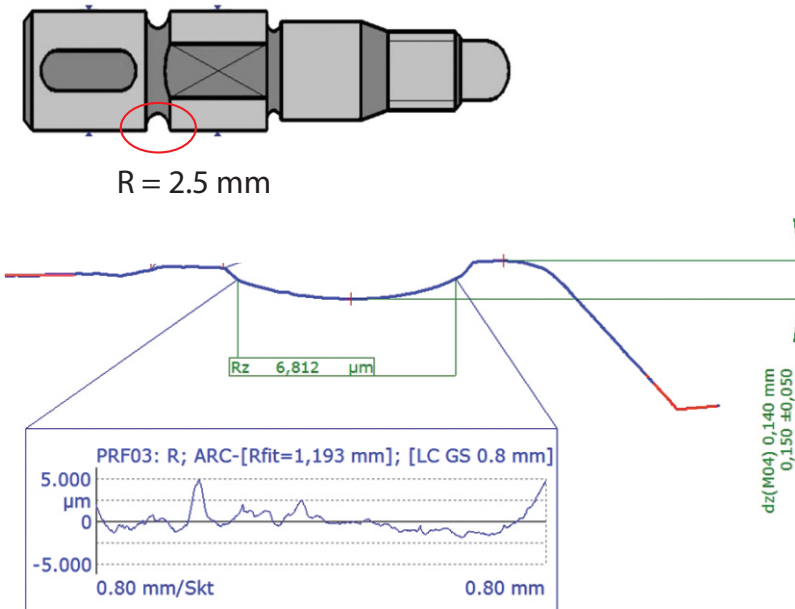

Key Highlights :

CNC-Controlled, Automatic Contacting

- Fully automated probe positioning and contact with the measurement surface.
- Eliminates operator influence for consistent, repeatable results.
- Ideal for multi-part, multi-feature measurement sequences with minimal human input.

System-Level Accuracy

- Precision mechanics ensure stable and reliable probe motion.
- Tactile measurement principle for true surface representation.
- Delivers lab-grade measurement performance in a compact system footprint.

MarWin Easy Roughness Software

- Simple, intuitive interface with pre-set measurement programs.
- Automatic evaluation of all key parameters (Ra, Rz, Rq, Rt, etc.).
- Quick reporting, data export, and traceability functions for digital QC.

Value & ROI Advantage

- Brings CNC automation and high accuracy at a fraction of full system cost.
- Maintenance-free operation through optimized drive design.
- Reduces inspection time and operator dependency — improving throughput and quality consistency.

Integration-Ready

- PC-based operation via MarWin Easy Roughness ensures seamless data management.
- Ready for connectivity with plant-wide quality systems and documentation platforms.

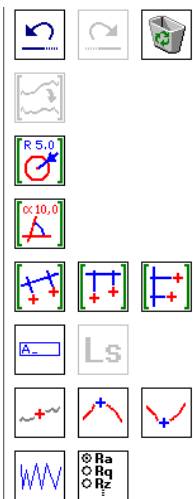

Order No.	6910290	6910296	6910297
Type	M 410	M 410 + Marwin Easy Roughness	MD 26 + Marwin Easy Roughness
Stylus	2μm/90° with 45° Approach Angle		
Rechargeable batteries	Li-Ion battery, 3.7V, nominal capacity 11.6 Wh, min. 1200 measurements		
Measuring principle	Skidless probe system		
Measuring Range	±250 μm (upto ± 750 μm with 3x probe arm length)		
Filter acc. to ISO/JIS	Gaussian filter as per ISO 11562 Filter as per ISO 13565	Gaussian filter as per ISO 16610-21 Filter as per ISO 13565-1	
Cutoff lc acc. to ISO/JIS	0.08 mm, 0.25 mm, 0.8 mm, 2.5 mm, automatic filter detection variable		
Number of Sampling length acc. to ISO/JIS	selectable 1 to 16		
Measuring Force	0.0007 mn		

Optional:
6820420 PRN 10 roughness standard incl. Mahr Calibration Cert.
PC, Monitor, UPS etc - optional.

Digimar | Mahr Digimar 816 CLT & 817 CLT – Precision Meets Productivity

Experience next-generation height measurement with the Mahr Digimar CLT series, combining precision, speed, and simplicity for shop-floor and quality-lab applications. Designed for ergonomic operation and intelligent connectivity, the Digimar 816 CLT and 817 CLT deliver reliable measurement results with maximum user comfort. Powered by a modern Windows-based operating system, the Digimar CLT series ensures seamless data handling, software integration and **annual firmware updates to keep your system current and future-ready.**

- **Touch-driven simplicity:** Large 10" touchscreen with clear, icon-based navigation and drag-and-drop functionality for effortless setup and program creation.
- **Instant online help:** On-screen guidance and contextual prompts ensure quick learning and reduce operator training time.
- **Animated probe calibration:** Step-by-step visual support simplifies calibration, enhancing repeatability and minimizing setup errors.
- **Calibration on the unit:** All calibration functions are performed directly on the instrument — no external software or PC required.
- **Motorized measuring slide:** Ensures consistent measuring force, removing operator influence and improving repeatability.
- **Wireless & USB connectivity:** Transfer measurement data seamlessly via MarConnect, or generate complete PDF reports directly on the device.
- **Measuring station capability:** Operates as a central measuring hub, capable of communicating with other Mahr instruments through wired connections for synchronized inspection and data collection.
- **Ergonomic design:** Dual handles with integrated air-bearing control provide smooth, effortless movement on the granite plate.
- **Battery-powered mobility:** Long-life rechargeable battery supports mains-independent measurement.

Important features for your quality assurance



Clarity

The touch display of the new Digimar 816 CLT & 817 CLT features even larger buttons that make recognition and operation even easier. They lead directly to the measurement and evaluation functions. This always ensures the reliable completion of measurements, setting and calculation functions, and the creation of measuring programs via Drag & Drop.



Extensive ports

The Digimar 816 CLT & 817 CLT has a variety of ports for backing up your measuring data. Data transfer is possible both wirelessly and by cable via the MarConnect duplex interface. The latter also transmits a measuring equipment ID, ensuring that your measuring results are traceable.

Integrate dial indicators

A port integrated in the slide enables error-free measurement of perpendicularity and straightness in conjunction with the Millimes 2000/2001 W digital dial comparators Marcator 1086R models.

Ergonomic handles

Handles on both sides guarantee that you can move your device precisely and effortlessly on the measuring plate. This allows the Digimar 816 CLT to be quickly moved into position and the measurement started.

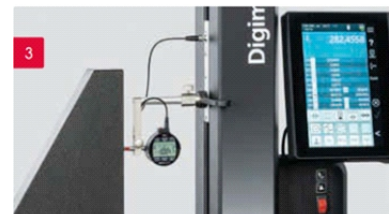



Mahr		hallo Header2 Header3	816 CLT Mahr
Rechtwinkigkeit			
Erstelldatum:	2024-02-16 08:04	Einheit:	mm
Gerät:	Digimar 816CLT 600mm / 24"	L _{90°} :	100.000 mm
Artikelnummer:	4429631	V _{90°} :	11 mm/s
Seriennummer:	32120001	— _{90°} :	0.500 mm
Messuhr:	MM2001W Mahr	Messpunkte	184
Artikelnummer:	00000000		
Seriennummer:	00000000		
Artikel	Bezeichnung		
Text1	Text2		
Kommentar			
L	100.000 mm		
\perp	-0.018 mm		
X MIN	0.000 mm		
X MAX	0.021 mm		
Q	0.0101*		
—	0.009 mm		
2024-02-16		Digimar 816 CLT - Rechtwinkigkeit 1/1	



Order No.	4429630	4429631	4429700	4429701	4429702
Type	Digimar 816 CLT		Digimar 817 CLT		
Measuring Range in mm	350	600	350	600	1000
Error limit in μm	(2.0+L/400) L in mm		(1.8+L/600) L in mm		
Plane repeatability in μm	1 μm		0.5 μm		
Bore repeatability in μm	2 μm		1 μm		
Control panel	10" tiltable		10" tilt, swivel and height-adjustable		
Function key design	Extra large		Standard		
Thumbwheel for fine positioning and quick measurement keys	-		x		
Squareness / Perpendicularity	Yes		Yes		
Pitch Circle Dia (PCD)	No		Yes		
Additional functions	-		Auto distance double probe measurement, cone function third zero point		
Measuring programs	Yes		Yes, including integrated ISO tolerance table		
Recording	PDF, Printer		PDF, Printer		
Data Transfer	MarConnect (USB or wireless)		MarConnect (USB or wireless)		

IDEAL FOR THE WORKSHOP

When you need to measure and check workpieces quickly in the workshop, trust Mahr's height measuring and scribing instruments.



Digimar 814 SR & 814 C Reliable Precision for Everyday Measurement

The Mahr Digimar 814 SR and 814 C height measuring instruments combine proven mechanical precision with easy, reliable digital operation. Designed for production environments and workshop applications, they offer the perfect balance between robustness, accuracy, and user-friendly handling.

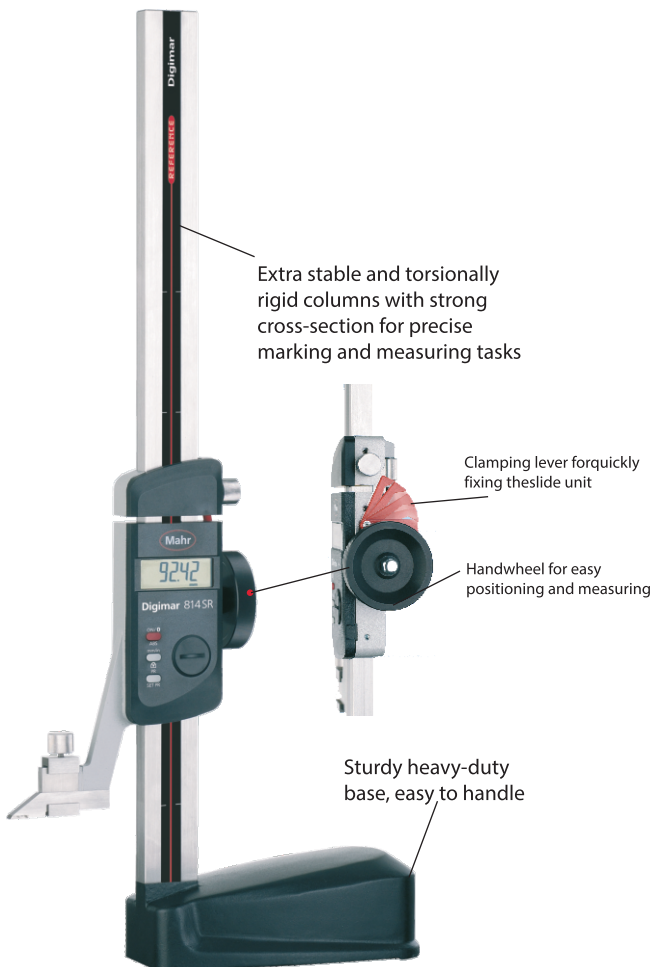

- **Rugged workshop design:** Built for daily use on the shop floor with stable construction, high repeatability, and smooth slide movement.
- **Easy and intuitive operation:** Clear function keys and a large, easy-to-read display ensure fast setup and error-free measurements.
- **Versatile measurement functions:** Accurately determine heights, depths, diameters, groove spacing, and distances between surfaces or edges.
- **Constant measuring force:** Guarantees repeatable and reliable results independent of operator influence.
- **Manual and digital flexibility:** The 814 SR offers reliable semi-digital measurement with high contrast display, while the 814 C adds advanced digital features and data interfaces for process documentation.
- **Data connectivity:** The 814 C supports data output via Opto RS-232C or MarConnect, enabling quick transfer to MarCom Professional software.
- **Ergonomic fine adjustment:** Smooth handwheel and fine-feed control for precise positioning and repeatable scribing or measurement tasks.
- **Battery-powered mobility:** Long operating time and independence from mains power make both models ideal for production-line use.



Applications

- Workshop height and scribing measurements.
- Dimensional checks of workpieces, steps, and grooves.
- Setup verification on machines and fixtures.
- QA inspection directly in production environments.

Scope of Delivery

- Digimar Height gage (814 SR or 814 C), Probe \varnothing 6 mm, CR2032 battery, Locking screw, Operating manual & works certificate. (814 C)
- Compatible accessories: Measuring cones (817 ks series), probes \varnothing 2–8 mm (814 m series).
- Whether you prefer the mechanical reliability of the 814 SR or the digital precision and connectivity of the 814 C, both models deliver accuracy you can depend on — every day, in every measurement.
- **Mahr Digimar 814 Series – Dependable performance. Precise results. Proven on the shop floor.**

Order no.	4426100	4426101	4426104	4426580	4426581
Type	Digimar 814 SR	Digimar 814 SR	Digimar 814 SR	Digimar 814 C	Digimar 814 C
Measuring range	350 mm	600 mm	980 mm	300 mm	600 mm
Resolution	0.010 mm	0.010 mm	0.010 mm	0.001 mm	
Error limit	$\pm 20 \mu\text{m}$	$\pm 25 \mu\text{m}$	$\pm 35 \mu\text{m}$	$\pm 7.5 \mu\text{m}$	$\pm 12.5 \mu\text{m}$
Typical Use	Robust manual height measurement and scribing			Digital measurement and data documentation with connectivity	

MarSurf CD 140 AG 11: All-rounder with intelligent probe system

Mahr has launched a new contour measuring machine on the market - the MarSurf CD 140 AG 11. Up to 70 mm probe range the stylus tips can be replaced quickly and without any tools - without having to recalibrate the system.

Toolless, magnetic probe tip holder, just click into place



- Z-axis with **quick adjustment**
- X Measuring Range **140mm**
- Probe Range **70mm**
- Probe Resolution **0.019µm**
- **Integrated Y-table with 60 mm TY adjustment**
- Automated **calibration routine**



Tangential Transition feature (Patented)

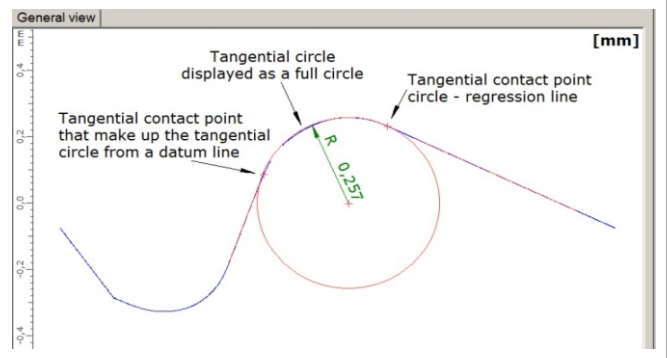

- Automatic evaluation, best adjustment of contours, CAD contour comparison and a lot more
- With option of roughness measurements
- Double probe tip
Measurement of double contours e.g. for the determination of diameters, threads (optional) etc.
- Automatic scanning force selection
 - a) Guarantees the correct probing force when changing between several probe tips
 - b) The probing force of the contour probing system can be individually adjusted to suit the measuring task.
- Free Stroke limit feature prevent probe from **Free fall**

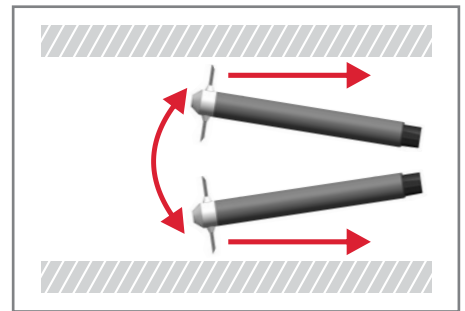

Order no.	6269200	6269201	6269202	6269203
Versions	without PC	with PC	without PC, with roughness option	with PC and roughness option
Tracing distance (in X) end	140 mm			
Resolution in Z	20 nm			
Measuring range in Z	70 mm			
Measuring force (N)	4 mN to 30 mN, in Z+ and Z-, adjustable via software			
Uncertainty of probe system (W-axis)	$\pm(0.4+1/(200 \text{ mm})) \mu\text{m}; 1 \text{ in mm}$			
Uncertainty of Displayed (X-axis)	$\pm(1.0+1/75) \mu\text{m}; 1 \text{ in mm}$			
Resolution in X	10 nm			

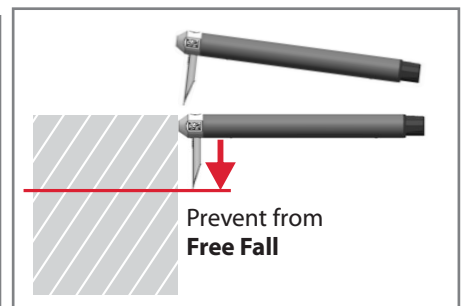

Precimar SM 350 / 650 / 1150

Motorized Setting-Benches:
Precision and Efficiency for Modern Dimensional Metrology

The new series of motorized setting-benches—SM 350, SM 650, and SM 1150—from PRECIMAR by Mahr GmbH redefines standards in precision, speed, and versatility for calibration and measurement environments. Engineered to meet the rigorous demands of modern quality assurance labs and calibration centers, these robust systems deliver fast, reliable, and highly accurate length setting solutions that streamline daily workflows.

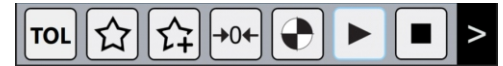

Quickly create favorites and scan via barcode



Accuracy 0.7 μm + L / 1000

Key Features and Advantages

- **Outstanding Accuracy:** All models boast a motorized positioning accuracy of 0.7 μm + L/1000, rivaling dedicated calibration devices like gauge blocks and setting rings, but with the convenience of automation.
- **Intuitive User Interface:** Equipped with a 10-inch full-color touchscreen, the system offers easy operation, allowing users to save favorites, recognize devices automatically, and control functions seamlessly.
- **Automated, Fast Positioning:** Motor-driven stepper motors enable quick, reproducible adjustments, reducing setup times and operator influence, thus boosting process reliability.
- **Flexible Measurement Range:** Available in three lengths—350 mm, 650 mm, and 1150 mm—to accommodate a variety of internal and external measuring instruments.
- **Versatile Accessories:** A comprehensive range of holders, bridges, supports, and adapter sets supports diverse gaging instruments such as Multimar, Marameter, bore and hand gages, simplifying setup and calibration tasks.
- **Comprehensive Data Management:** Calibration data is stored securely in the system, and updates can be deployed rapidly via web or USB, ensuring persistent compliance and system integrity.

Technical Specifications at a Glance

Feature	SM 350	SM 650	SM 1150
Measuring Range	350	650	1150
Accuracy (μm)	0.7 + L/1000, L in mm		
Resolution (mm)	0.001 / 0.0001		
Repeatability (μm)	0.5		
Display	10" color touchscreen		
Connectivity	3 x USB 3.1, 1 x Mini-USB		

Service & Software:

- Regular firmware and software updates available via download
- Onboard calibration data for simplified service
- Password-protected access for system maintenance

Application Spectrum

These setting-benches are ideal for:

- Calibration laboratories requiring rapid, precise length setting of internal and external gages.
- Manufacturing quality control aiming for high throughput with minimal error.
- Organizations seeking to modernize their measurement processes through digital equipment management and error tracking.
- Setting and verification of measuring devices such as bore gauges, dial indicators, and other internal and external measurement tools.

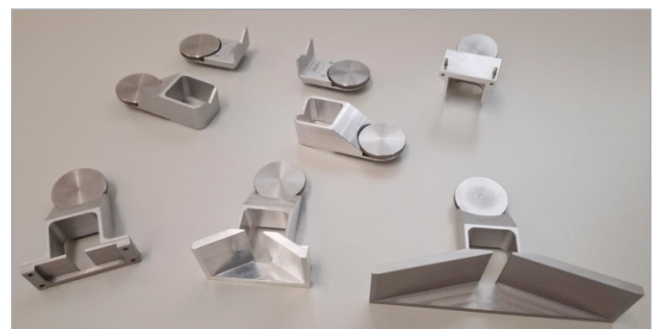

Accessories

Order No.	Description	
5358701	SM-Pa holder outer	for setting-bench
5358702	SM-Pi holder inner	for setting-bench
5358703	SM-Bk bridge small	Internal measuring devices 18-35mm
5358704	SM-Bm bridge middle	Internal measuring devices 35-90mm
5358705	SM-Bg bridge big	Internal measuring devices 90-300 mm
5358706	SM-Ha height support	for universal measuring devices

Precimar SM 350 / 650 / 1150

Motorized Setting-Benches:
Precision and Efficiency for Modern Dimensional Metrology

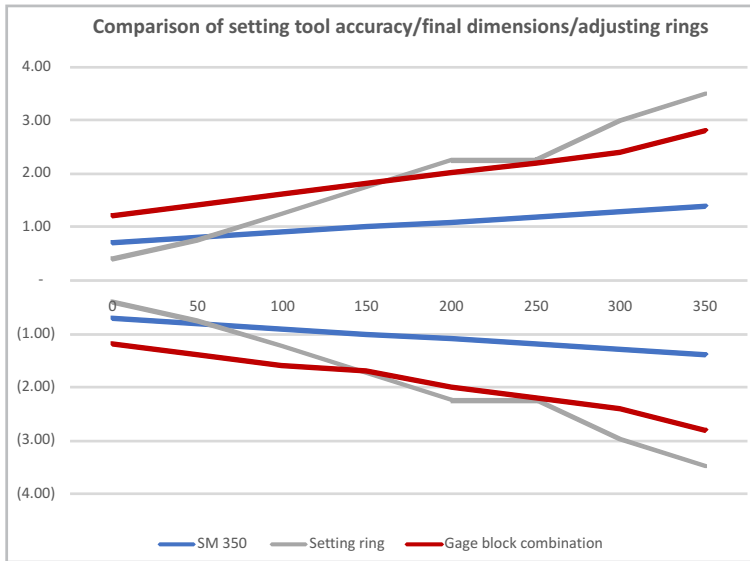

Order No.	Model
5357400	Precimar 350 setting bench
5357401	Precimar 650 setting bench
5357402	Precimar 1150 setting bench

Bigger Size also available on demand



Conclusion

The PRECIMAR SM series offers a comprehensive, adaptable, and future-proof solution for the demanding field of precision measurement and calibration. Combining high accuracy, automation, ease of use, and flexible accessories, these benches significantly enhance productivity, measurement reliability, and operational safety—ideal for any measurement-critical environment.

Precimar SM 60-V | Length Measuring Bench

Combination Talent for a Wide Range of Form Measurements

The Precimar SM 60-V is a mobile measuring bench with interchangeable anvils, designed for quick and easy outer measurements on cylindrical parts, thicknesses, and lengths. Developed by Mahr, this user-friendly instrument excels in production environments with its robust design and adaptability.



Versatile

The length measuring bench can be adapted to a wide range of measuring tasks thanks to an extensive portfolio of measuring anvils.

Key Advantages

- Quick adjustment to workpiece diameters up to 60 mm
- Versatile thanks to an extensive range of measuring anvils

Applications

- Rapid measurements of cylindrical parts,
- Thickness and length measurements
- Determining pitch diameter of external threads (with thread flank anvils)
- Gear measurements (with sphere or roller anvils)

Technical Data :

Order no.	5357360	5357380
Type	SM 60	SM 60-V
Measuring range	0-60 mm	0-60 mm
Distance of moveable anvil	25 mm	25 mm
Measuring Face	6H7 mm	6H7 mm
Measuring force (N)	1 ± 0.2 N	5 N
Large support table, infinitely height adjustable	Ø 60 mm	Ø 60 mm
Mount for Dial indicator or probe	Ø 8	Ø 8

Marsurf Engineering Solutions

Surface Finish Bore Measuring Gages

The MarSurf Engineered family of custom portable gages for bores are designed to perform surface finish measurements that cannot be completed with traditional laboratory instruments.

On the shop floor or in the measuring room, certain features are typically measured with portable instruments:

- Deep, blind, interrupted or through holes
- Hard-to-reach or partially obstructed surfaces
- Parts that are too large to be placed on a measuring station

For example, the following applications present difficult-to-reach measuring locations:

- **Engine parts** : engine blocks, cylinder heads, crankshafts, connection rods, etc.
- **Transmission parts** : valve bodies, etc.
- **Pump components** : housing, etc.
- **Aerospace** : landing gear parts, shafts, etc.

A wide range of applications is covered – anything from small to large diameters and to low to high measurement depths, among others, as follow :

MBF and MVG Gages Advantages

- A handle that completely encapsulates the measurement drive unit and stylus, providing total protection for these critical components
- An automatic probe protection mechanism that lowers the stylus during the measurement cycle.
- A calibration stand, included, provides for convenient storage and one step calibration
- The gage ensures that the measurements are performed in the correct orientation relative to the machining lay pattern on the parts to be measured

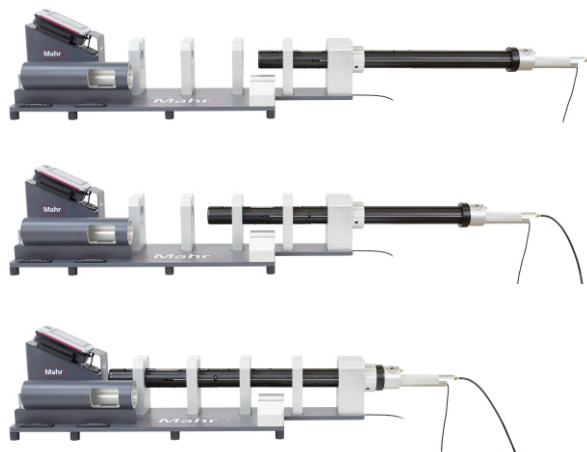

MBF Surface Finish Measuring Gage



MCR Surface Finish Measuring Gage

Typical Applications for the MBF and MVG Gages

- **Engine blocks** : oil level indicator bore, counterbalance shaft bore, crankshaft sensor bore, cylinder bore, crankshaft bore
- **Gearbox components** : gear I.D. and O.D., transmission housing features
- **Cylinder heads** : camshaft bore (all), fuel pump lifter bore, injector bore, camshaft sensor bore, cup plug hole
- **Connecting rods** : main bore, pin bore
- **Aerospace parts** : landing gear bores, hydraulic bores, pump body
- Valve guides (MVG type exclusively)

MCR and MCB Gages Advantages

- Automatic pneumatic probe retraction (Drive unit protection) during insertion/removal into bore area
- Diameter auto sizing feature to allow measurements for a variety of bore size ranges, eliminating the need to use several dedicated gages
- Integrated part cleaning prior to measurement (for devices with diameter larger than 70 mm)
- Calibration/fixture stand with fixed calibration master

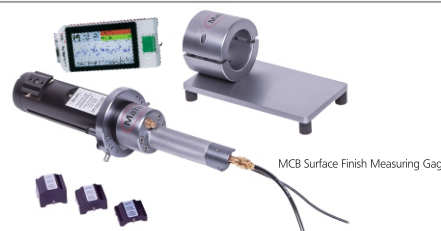

MCB Surface Finish Measuring Gage



MCR Features

- For the measurement of any part with deep bores
- Integrated mechanical stop/handle assembly with fixed depth indicator for repeatable gage positioning (enables the measurement of all the crankshaft bores on an engine block)
- Clamps within the engine block for stable measurements
- Delivers the drive unit directly above the measuring surface without the use of a long measuring probe extension (increases cycle life of the drive unit, eliminates burnishing of the part, helps to protect the stylus)

MCB Features

- For the measurement of cylinder walls, sleeves or any bore requiring surface finish measurements
- Enables fast and easy measurements without setup (production environment or in a machining center)
- The gage self-aligns to the bore and automatically establishes the correct measurement direction
- The gage has hands-free operation – it reduces the effect of operator influence on measurements
- Adjustable mechanical stop with depth indicator for repeatable gage positioning



Marsurf Engineering Solutions

Surface Finish Bore Measuring Gages

Bore and Depth Measuring Range Capability Based on Gage Type

	Type of Bore Depth	Diameter Measuring Range	Depth Measuring Range	Dedicated to Specific Diameter and Depth	Variable Bore Diameter and Depth	Probe Retraction	Probe
MBF 3 (with PHT 3 pickup)	Low Depth	6 mm to 16 mm / 0.23 in to 0.63 in	5 mm to 10 mm / 0.19 in to 0.39 in	✓		Mechanical	Inductive Skidded Probe
MBF 3 with (with PHT 6 pickup)	Low Depth	16 mm to 150 mm / 0.63 in to 5.9 in	10 mm to 280 mm / 0.39 in to 11.02 in	✓		Mechanical	Inductive Skidded Probe
MCB 1	Medium Depth	55 mm to 77 mm / 2.16 in to 3 in	20 mm to 257 mm / 0.78 in to 10.11 in		✓	Pneumatic	Inductive Skidded Probe
MCB 2	Medium Depth	74 mm to 112 mm (to 150 mm with expansion pads) / 2.91 in to 4.40 in	25 mm to 225 mm / 0.98 in to 8.85 in		✓	Pneumatic	Inductive Skidded Probe
MCB 3	Medium Depth	121 mm to 170 mm / 4.76 in to 6.69 in	25 mm to 350 mm / 0.98 in to 13.77 in		✓	Pneumatic	Inductive Skidded Probe
MCR 2	High Depth	50 mm to 170 mm / 1.97 in to 6.69 in	100 mm to 1000 mm / 3.93 in to 39.3 in		✓	Pneumatic	Inductive Skidded Probe
MVG 2 (with PHT 3 pickup)	Only Valve Guides on Cylinder Heads	6 mm to 16 mm / 0.23 in to 0.63 in	5 mm to 10 mm / 0.19 in to 0.39 in	✓		Mechanical	Inductive Skidded Probe

MarForm MMQ 100 with MarWinEasyForm

The simplest, most robust form measuring solution for production



The **MarForm MMQ 100** is the ideal form measuring instrument for production environments where speed, simplicity and reliability are essential.

Combined with the **MarWinEasyForm software** offers the easiest operation ever achieved on a high-precision form tester.



Key Advantages

- Touchscreen operation – intuitive, fast, minimal steps
- Extremely short measurement cycles – roundness in as little as two simple touches
- Large measuring volume with precise mechanical bearings
- Robust – suitable for shop-floor use
- No compressed air required
- Optional digital probes in Z and X for direct data transmission
- Portable – can be powered via laptop outlet

MarWinEasyForm Software Highlights

- 3D interactive user interface for immediate program creation
- Clear grid-line preview and instant result display
- Teach-in mode – learn and save measurement sequences by simply performing them once
- Automatic storage of records (on PC or network)
- Supports user administration and network integration

Optimized for frequent form measuring tasks

- Roundness (also in a section)
- Flatness (from a circle)
- Concentricity
- Coaxiality
- Radial run-out
- Axial run-out
- Plane parallelism from opposite circles
- Fourier/waviness analysis

(1) - from a polar trace

MarForm MMQ 100	
Length Horizontal Unit, X axis	1840 mm, manual
Vertical Unit, Z Axis	300 mm, manual
Centering and Tilting Table	20 kg max load, manual
Roundness Deviation	0.05 μm + 0.0006 $\mu\text{m}/\text{mm}$
Axial Runout Deviation	0.04 μm + 0.0006 μm

Mahr



Product Catalog

Mahr Metrology India Pvt. Ltd.

(A 100% Subsidiary of Mahr GmbH)

B-6, Reddipalayam Road, 4th Street,

Mogappair West Estate,

Chennai-600037

Board: +91 44 4617 5555

Email: mahrindia@mahr.com

www.mahr.com

Authorised Distributor :



Email: info@ssmithtechnologie.com

BENGALURU

#85/143, 9th Main, Dhuggamma Layout, Peenya 3rd Stage,
Bengaluru - 560058.

Ph: +91 95388 35190 / 95133 20338

HOSUR

#C1B1, Ground Floor, New ASTC Hudco, 100 Ft Road,
Avvai Nagar, Hosur - 635109.

Ph: +91 98431 20336 / +91 95388 35190

© Mahr GmbH

We reserve the right to make changes to our products, especially due to technical improvements and further developments.

All illustrations and technical data are therefore without guarantee.

3765158-EN | 01.2026