

FIRST-CLASS COORDINATE MEASURING MACHINES

WENZEL CMMs

Precision that pays off



PRODUCT RANGE
COORDINATE MEASUREMENT METROLOGY

WENZEL – INNOVATION MEETS TRADITION



“With our product range we are able to support all your measuring needs. As a family business, we strive to achieve long-term partnerships with our customers and for this we invest in the outstanding quality of our machines and offer you excellent service.

Dr. Heike Wenzel and Prof. Dr. Heiko Wenzel-Schinzer
Management of the WENZEL Group

WENZEL FACTS

About WENZEL:

Founded in 1968
100 % family owned business in 2nd Generation

Subsidiaries and agencies

in more than 50 countries

Installed machine base worldwide:

> 10.000

Number of employees worldwide:

> 600

Headquarters:

Wiesthal, Germany

Total area:	54.000 m ²
of which buildings:	15.500 m ²
of which air-conditioned:	5.000 m ²

The WENZEL Group GmbH & Co. KG is a leading Manufacturer of innovative measuring technology solutions. The success of the largest family-run company in the industry is based on German quality, technology, flexibility and strong partnerships.

Founded in 1968, the name WENZEL stands today primarily for the highest precision, reliability and technological competence.

In recent years, measurement technology has changed a lot. The measuring tasks are performed in production as well as in the measuring room. In addition to high-precision tactile measurement, optical sensors as well as new technologies such as computed tomography have found their place in metrology. We as WENZEL have brought numerous innovative solutions onto the market in recent years so as to offer our customers the right products. In addition to the product itself, we also supply you with turnkey solutions. This makes us flexible experts for innovative measurement solutions.

WENZEL SOLUTIONS

VERSATILE APPLICATIONS

OUR APPLICATIONS



OUR PRODUCT LINES

OUR FOCUS INDUSTRIES

Measurement technology has been our profession since 1968 and we have developed it to absolute perfection over the years. WENZEL stands for highest quality standards and reliability - without forgetting that only those who have their sights set on the future and their vision constantly in mind can survive.

The success of our CMM series is based above all on a coherent overall concept and unconditional perfection in detail. The principle behind the success of this series is mechanical accuracy and top mechanical engineering. The bridge machines have air bearing guide elements in all axes which ensure wear-free and smooth operation. High precision and user-friendly operation, all rounded off by an intelligent service package - WENZEL thinks ahead. The machines can be equipped with a variety of swivel head and stylus combinations, from rigid heads to motorized rotary heads, from simple probes to high-precision measuring probe systems.

The optimal solution for every measuring task!

TYPICAL BUSINESS AREAS

- Quality assurance
- Product development
- Surface testing
- Prototype creation
- First article inspection
- Fabrication

TYPICAL APPLICATION AREAS

- Mechanical engineering
- Automobile manufacturers and suppliers
- Aerospace
- Foundry technology
- Metal and plastics processing industry
- Medical technology
- Mold and tool making
- Electrical engineering/electronics
- Inspection services
- Research and Science

PRECISION THAT PAYS OFF

WENZEL BRIDGE CMMs

RANGE OF SERVICES AND FIELDS OF APPLICATION AN OVERVIEW

With the help of coordinate measuring technology, dimensional measured variables of standard geometric elements or free-form surfaces of individual parts, moulds, models and tools can be recorded. The elements are picked up at the workpieces and their measuring points are then processed further on computer. The development of coordinate measuring machines has made it possible to perform measuring tasks faster and with very high accuracy. Coordinate measuring technology is therefore indispensable in today's industrial production process.

Measurement technology has been WENZEL's profession since 1968 and in 1980 the first coordinate measuring machine developed by WENZEL was introduced. Since then, WENZEL has been one of the world's leading suppliers of coordinate measuring machines and the largest family-run company in the industry. Today, the name WENZEL is synonymous with highest precision and innovation in the fields of coordinate measuring technology, computer tomography and high-speed scanning.

With coordinate measuring machines from WENZEL almost all measuring tasks can be mastered. The success of WENZEL's customers depends on the performance of its products and services. Their demands for quality and precision are constantly increasing. WENZEL takes up this challenge every day with the aim to convert the needs of the different industries into efficient products.

The offer extends far beyond the machine configuration: For special requirements WENZEL has tailor-made solutions ready: From the conception and planning to the turnkey handover. In addition to the production and installation of the measuring instruments, this includes,

for example, the necessary static calculations as well as the complete installation of the measuring room including the control and safety technology. Starting with the floor construction up to the software configuration - WENZEL makes almost everything possible.



OVERVIEW

CMM PRODUCT RANGE

COORDINATE MEASURING METROLOGY „MADE BY WENZEL“

WENZEL offers well-engineered coordinate measuring machines (CMMs) which have proven themselves many times in the market. In this brochure we present the LH series of CMMs. The LH series bridge CMMs have air bearing guide elements in all axes which ensure wear-free and smooth operation. The LH base plates as well as

traverses and quills are made of granite. Granite's physical properties make it the perfect material for measuring instruments. The LH series distinguishes itself by its high accuracy and high measuring speeds.

OUR SIZES – SUITABLE FOR YOUR MEASURING TASKS

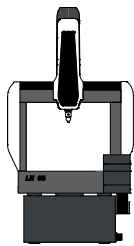

LH 65...

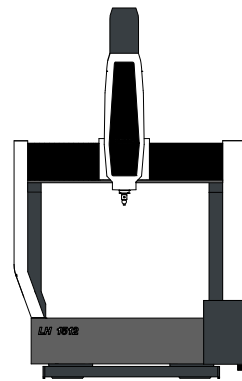

LH 1512...

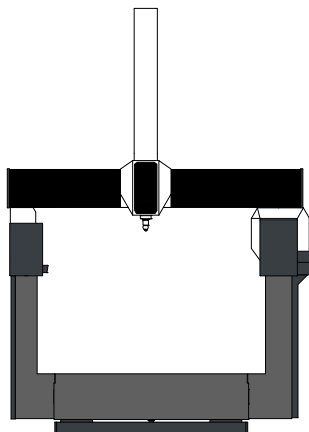



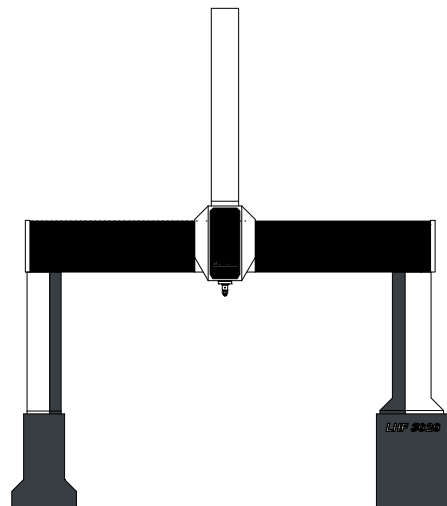











LH 2015...

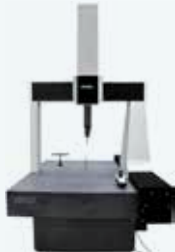

LH 3020...

ACCURACY | GENAUIGKEIT [µm]

<1		 0,8 + L/ 450		 0,8 + L/ 450	
1	 1,5 + L/ 350	 1,0 + L/ 400  1,2 + L/ 350	 1,5 + L/ 350	 1,0 + L/ 400  1,2 + L/ 350	
2	 2,0 + L/ 300		 2,2 + L/ 300		
3					
 <p data-bbox="352 2002 464 2047">XO 55</p>	 <p data-bbox="679 2002 786 2047">LH 65</p>	 <p data-bbox="999 2002 1110 2047">XO 87</p>	 <p data-bbox="1329 2002 1437 2047">LH 87</p>		

 1,0+
L/ 450

 1,2+
L/ 400

 1,4+
L/ 350

 1,8+
L/ 350

 1,9+
L/ 450

 2,1+
L/ 400

 2,3+
L/ 350

 2,0+
L/ 450

 2,2+
L/ 400

 2,5+
L/ 350

 2,6+
L/ 300

 2,8+
L/ 450

 3,0+
L/ 350

 3,3+
L/ 300



XO 107



LH 108

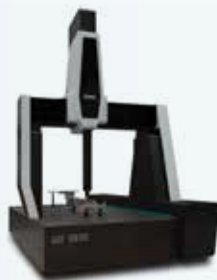

LH 1210



LH 1512



LH 2015

ACCURACY CLASSES

THE RIGHT SOLUTION FOR EVERY REQUIREMENT STANDARD | PREMIUM | PREMIUM-SELECT

WENZEL LH coordinate measuring machines are available for different accuracy requirements in three accuracy classes:

Standard | Premium | Premium Select

The already high-precision standard version coordinate measuring machines are surpassed by the Premium and Premium Select models due to even more precisely machined mechanical components, selected materials, optimized acceptance procedures and additional options.

WENZEL ACCURACY CLASSES AT A GLANCE





- Perfect interaction of the machine components
- Identical thermal behavior of the granite in all axes
- Manual temperature compensation
- High-resolution scales
- State-of-the-art Sensors (tactile, scanning, optical)
- Innovative drive, bearing and guidance technologies
- Modular design for retrofitting



- Online temperature compensation
- More elaborate premium acceptance procedure with tighter tolerances for better CAA Compensation (Computer Aided Accuracy)



- Use of the highest quality granite for the base plate, cross-beam and sleeve
- WENZEL-specific air bearing technology
- Grinding and lapping processing up to the mechanically feasible limit
- Higher resolution length measuring systems
- Premium Select Acceptance Procedure for optimal CAA Compensation (Computer Aided Accuracy)
- Inherent mechanical accuracy

WENZEL XOrbit Series

YOUR ENTRY INTO COORDINATE METROLOGY

The WENZEL XOrbit is the ideal coordinate measuring machine for when the essential elements of measurement are important and when speed and ease of operation are required. The XOrbit coordinate measuring machine offers an excellent price-performance ratio and can be equipped with multiple changeable measuring sensors. Its flexibility and suitability for a wide range of applications

make the XOrbit an effective all-rounder. The consistent approach and intelligent machine concept makes it an economical entry into coordinate measuring technology. Simple measurement - simply good. CMMs of the XOrbit series are available in the accuracy classes Standard and Premium.

FEATURES

- **Economical to use** due to a favorable price-performance ratio
- Emphasis on **unlimited functionality** from WENZEL's decades of experience
- **Use of granite** in all axes ensures identical thermal behavior
- **Excellent long-term stability** due to air bearing guides incorporated into the granite base plate and high-precision lapped guide surfaces
- **Good accessibility** facilitates maintenance work

FIELDS OF APPLICATION

The XOrbit is the all-rounder for every field of application when it comes to measuring standard geometries and free-form surfaces. The XOrbit fulfills all important roles from use in incoming goods through to final inspection. For single or serial parts - the XOrbit is universally applicable.

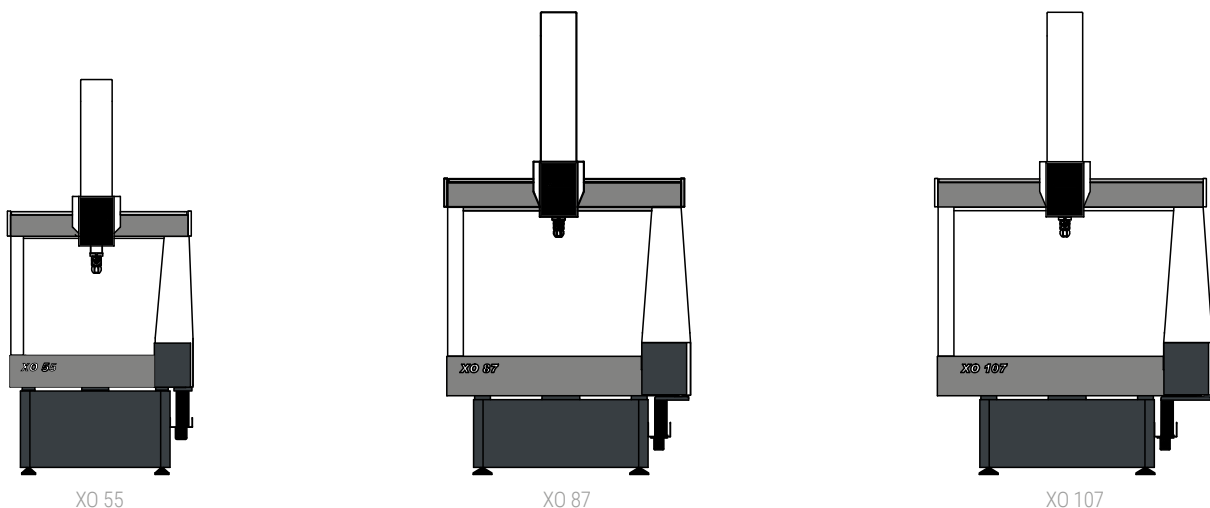

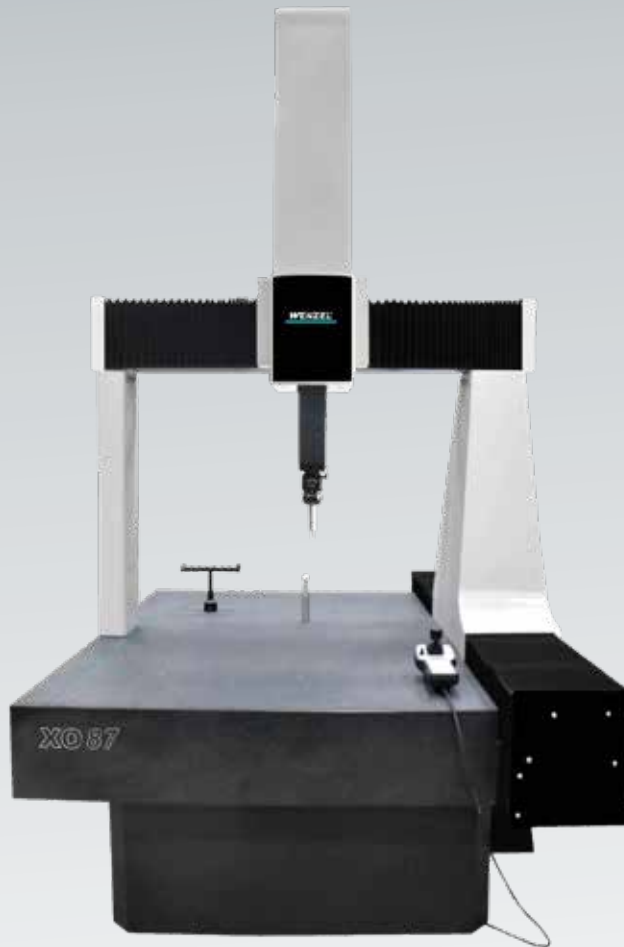

MEASURING ACCURACY

Typ	Measuring ranges X x Y x Z (mm)	Volumetric length measuring uncertainty $E_{L, MPE}$ (µm) Premium
XO 55	500 x 500/700/1000 x 500	1,5 + L / 350
XO 87	800 x 1000/1500 x 700	1,6 + L / 350
XO 107	1000 x 1500/2000 x 700	1,8 + L / 350

Value $E_{L, MPE}$ only valid for SP80/SP25M touch probes.

Other Y-lengths on request. Subject to changes in design and scope of delivery as well as further technical development.

YOUR ADVANTAGES AT A GLANCE

- Cost-effective introduction to coordinate measuring technology**

Excellent price-performance ratio | WENZEL High quality

- High mechanical precision**

Granite base | Hand-lapped base plate (DIN 876/0) |
Air bearing guide elements in all axes

- Low operating costs**

Low air consumption | RENISHAW sensors |
Reliable and inexpensive spare parts

- High flexibility**

Bellows covers for protection against contamination |
Data compatibility with other WENZEL systems |
Automation solutions

- Versatile sensor options**

Changeable sensor systems | 3-axis scanning |
Optical sensors

WENZEL LH SERIES

THE FAST AND EASY WAY TO EXACT MEASUREMENT RESULTS

With the LH you benefit from an extremely functional, effective and flexible measuring machine that is reliable and easy to operate. The success of our coordinate measuring machines is based on a proven holistic concept consisting of first-class mechanical engineering, intelligent software and accessory options and a comprehensive service package. Stable, reliable and fully dynamic, the LH is a universal and flexible measuring

instrument for a wide range of applications. With the current generation of air-bearing bridge machines, WENZEL continues the progress in precision, efficiency and longevity. With its revolutionary design, the LH impresses with high mechanical accuracy, perfect ergonomics and increased dynamics. CMMs of the LH series are available in the accuracy classes Standard, Premium and Premium-Select.

FEATURES

- **High-quality machine components** harmonize in perfect interaction and ensure long machine running times
- **Excellent long-term stability** due to air bearing guides incorporated into the granite base plate and high-precision lapped guide surfaces
- **Identical thermal behaviour** of granite in all axes
- **High-resolution scales** ensure exact positioning and precise measurement results
- **Innovative sensor technology** ensures precise detection of free-form surfaces and geometric elements
- **Perfect working ergonomics** for comfortable and safe operation
- **Highest investment security:** Modular design ensures future upgrade of the CMM

FIELDS OF APPLICATION

The LH is ideal for all applications requiring high accuracy and high throughput. The LH series is used in almost all areas of industry and measures components in detail from watch manufacture through to the production of large engines. The Y-axis can be customized in length for special sizes.

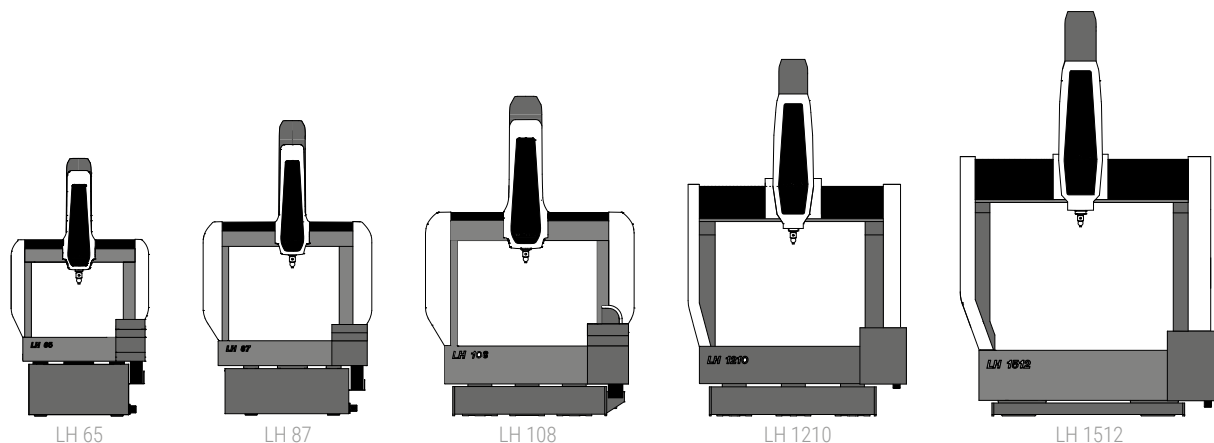



MEASURING ACCURACY

Type	Measuring ranges X x Y x Z (mm)	Volumetric length measuring uncertainty $E_{L, MPE}$ (μm) Premium Select
LH 65	650 x 750/1200 x 500	0.8 + L / 450
LH 87	800 x 1000/1500/2000 x 700	0.8 + L / 450
LH 108	1000 x 1200/1600/2000/3000 x 800	1.0 + L / 450
LH 1210	1200 x 1600/2000/2500/3000 x 1000	1.9 + L / 450
LH 1512	1500 x 2000/2500/3000 x 1200	2.0 + L / 450

Value $E_{L, MPE}$ only valid for SP80/SP25M/REVO touch probes.

Other Y-lengths on request. Subject to changes in design and scope of delivery as well as further technical development.

YOUR ADVANTAGES AT A GLANCE

■ Highest mechanical precision

Granite in all axes | Handcrafted |
Unique mechanical precision

■ Low operating costs

Low air consumption | Fast availability of reliable spare
parts

■ High flexibility

Customer-specific measuring volume |
Data compatibility | Suitable for automation

■ Versatile sensor options

Changeable sensor options | 3- or 5-axis scanning |
Optical sensors

■ Ergonomic design

Easy to operate | Ease of maintenance |
Aesthetic design

THE LH-FEATURES

PRECISE IN DETAIL

- Base plate, traverse and quill made of dark natural hard stone, thus ensuring identical thermal behaviour on all axes
- Y-axis guide system integrated directly into the base plate
- Weight compensation of the Z quill by means of a controlled pneumatic cylinder
- Available with active vibration damping
- Air bearing guide elements in all axes for wear-free, smooth-running operation
- Usable surface of the base plate machined according to DIN 876/0
- X- and Y-axis guidance with bellows cover
- CNC control of all axes
- Compact size
- Good accessibility for maintenance work

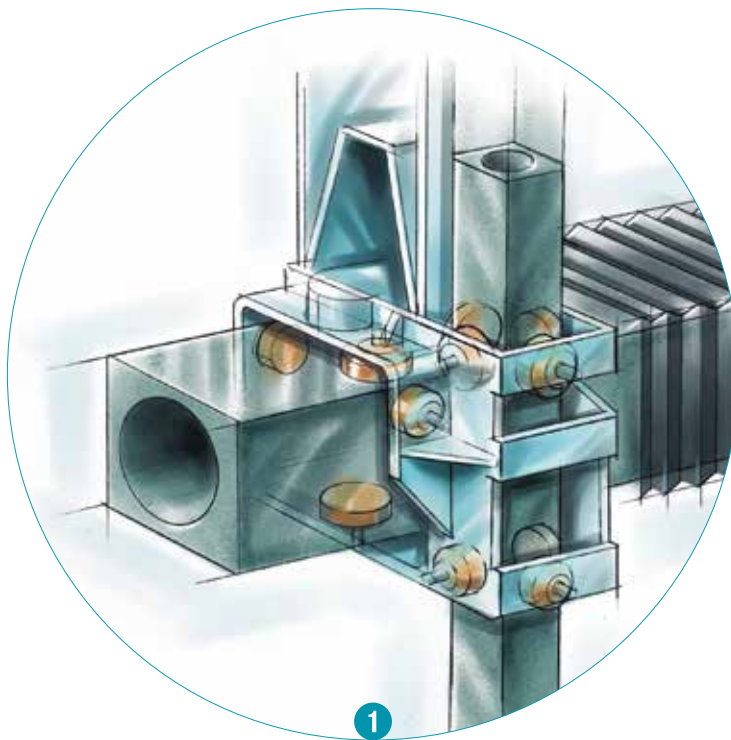

Components optimized by FEM/CAD guarantee maximum rigidity with reduced moving masses.

Symmetrical guide profiles with reduced wall thicknesses: optimum for predictable expansion behaviour at changing operating temperatures. Bellows protect the traverse as well as the Y-guide against environmental influences.



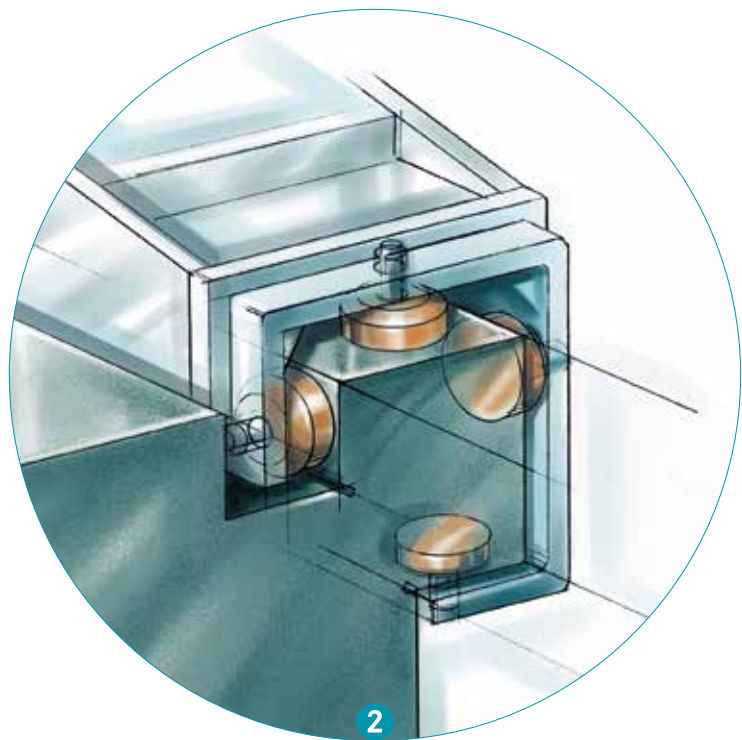
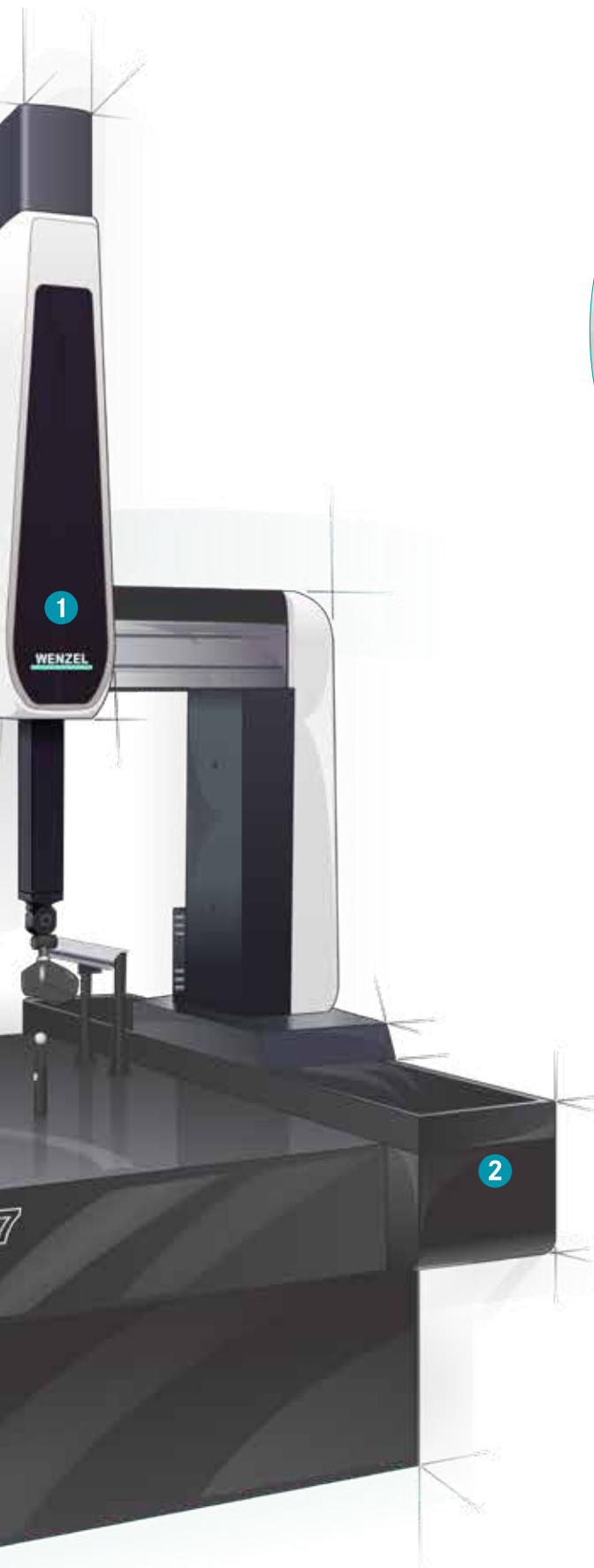

Preloaded air bearing guides in the Y-axis with high-precision lapped guide surfaces incorporated into the granite base plate: a guarantee for excellent long-term stability.

WENZEL LH GANTRY SERIES

PRECISE RESULTS WHEN MEASURING LARGE COMPONENTS

The LH Gantry is a CNC coordinate measuring machine with air bearings in all axes. It offers all the advantages and application possibilities of the LH Series and has also been specially designed for the inspection of large-volume and heavy workpieces. The raised guides in the Y-axis also ensure maximum stability and rigidity, even with dynamic movements. Overall, the machine body forms an inherently stable, homogeneous unit with optional integrated active vibration damping, which does

not require a separate foundation. Thermal environmental influences affecting the workpiece and the CMM can be corrected by means of automatic temperature compensation (optional). The optional use of a rotary table means that even large rotationally symmetrical components can be measured flexibly and accurately. LH Gantry series measuring machines are available in Standard, Premium and Premium Select accuracy classes.

FEATURES

- **Long-term stability** and high mechanical precision due to granite machine structure
- **Homogeneous machine structure** and integrated vibration damping (optional), no need for a separate foundation
- **Highest stiffness** and stability due to high drive, bearing and guide components in the Y-axis
- **High dynamics** due to double drive (LH 2015 / LH 2317) in the Y-axis and backlash-free friction drives
- **High wear resistance** and freedom from residual stress due to robust granite design
- **Maintenance-friendly** thanks to maximum spare parts availability and easily accessible replacement components

FIELDS OF APPLICATION

Stable, reliable and fully dynamic, LH Gantry machines are universally and flexibly applicable for a wide range of applications. Typical areas of application are, for example, the measurement of large engines, large gears or heavy machine components.

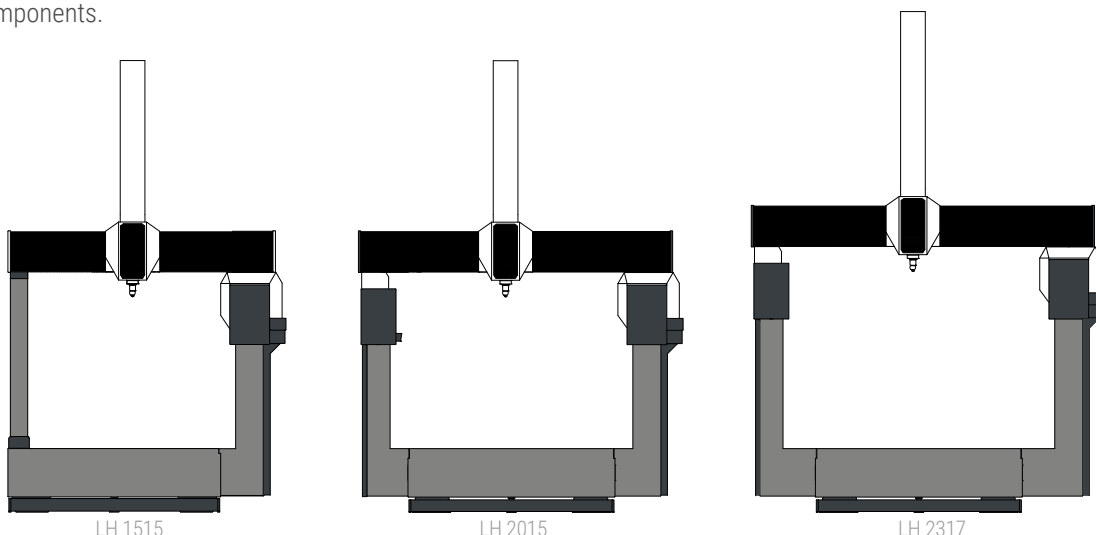

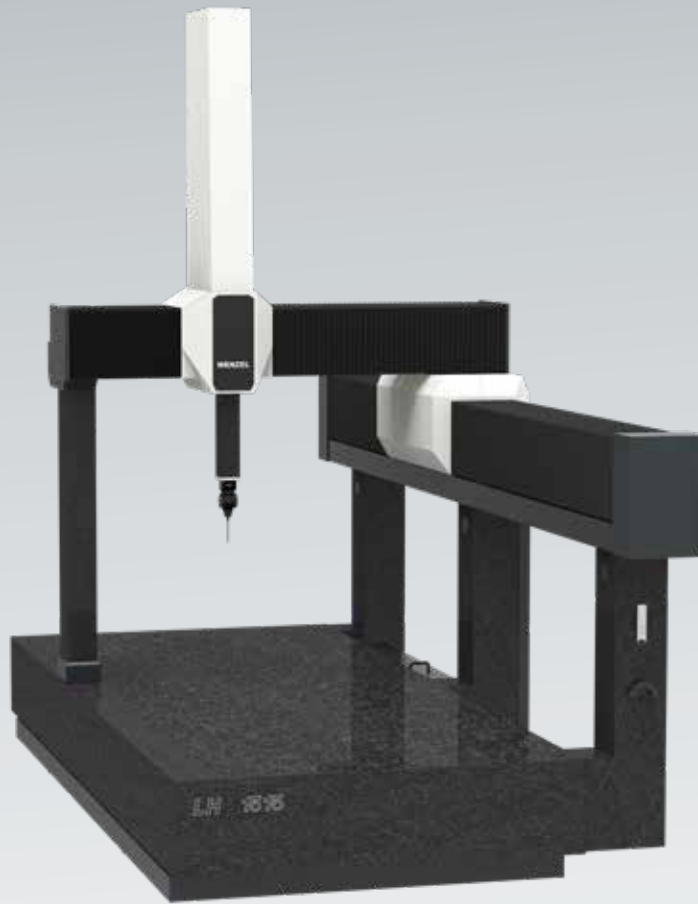

MEASURING ACCURACY

Type	Measuring ranges X x Y x Z (mm)	Volumetric length measuring uncertainty $E_{L, MPE}$ (μm) Premium Select
LH 1515	1500 x 2000/3000/4000 x 1500	2,5 + L / 450
LH 2015	2000 x 3000/4000/5000 x 1500	2,8 + L / 450
LH 2317	2300 x 4000/5000/6000 x 1750	3,1 + L / 450

Value $E_{L, MPE}$ only valid for SP80/SP25M/REVO touch probes.

Other Y-lengths on request. Subject to changes in design and scope of delivery as well as further technical development.

YOUR ADVANTAGES AT A GLANCE

- Air bearing guide elements in all axes**
 High mechanical precision | Granite base | Handcrafted
- Low operating costs**
 Low air consumption | Reliable and inexpensive spare parts
- High flexibility**
 Customer-specific measurement volume |
 Data compatibility with other WENZEL systems |
 Automation solutions
- Versatile sensor options**
 Switchable sensor systems | 3- or 5-axis scanning |
 Optical sensors
- Ergonomic design**
 Simple operation | Simple maintenance |
 No foundation necessary

THE LH GANTRY-FEATURES

GUIDANCE FROM ABOVE FOR STABLE DYNAMICS

Air bearing guide elements in all axes of the LH Gantry ensure wear-free operation and optimum guidance characteristics. The same thermal behaviour of all axes is guaranteed by a base plate, traverse and quill made of dark natural hard stone. The stiff construction in combination with a double drive of the Y-axes guarantees highest

dynamics and stability at the same time. Overall, the machine body forms an inherently stable, homogeneous unit with integrated active vibration damping, which does not require a separate foundation.

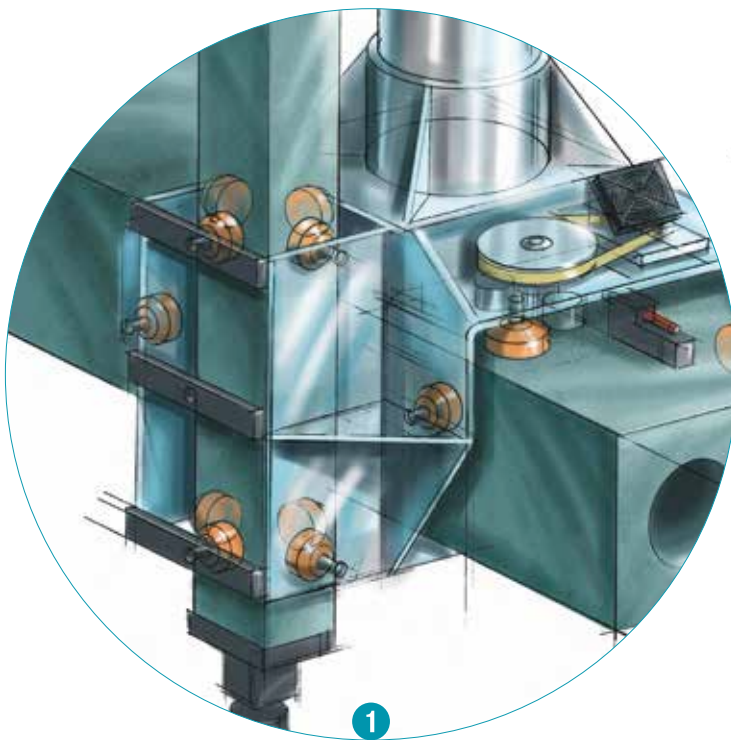

Symmetry everywhere

- Optimized air bearing with "broad base"
- Perfection in detail
- Service friendliness
- Thermal stability

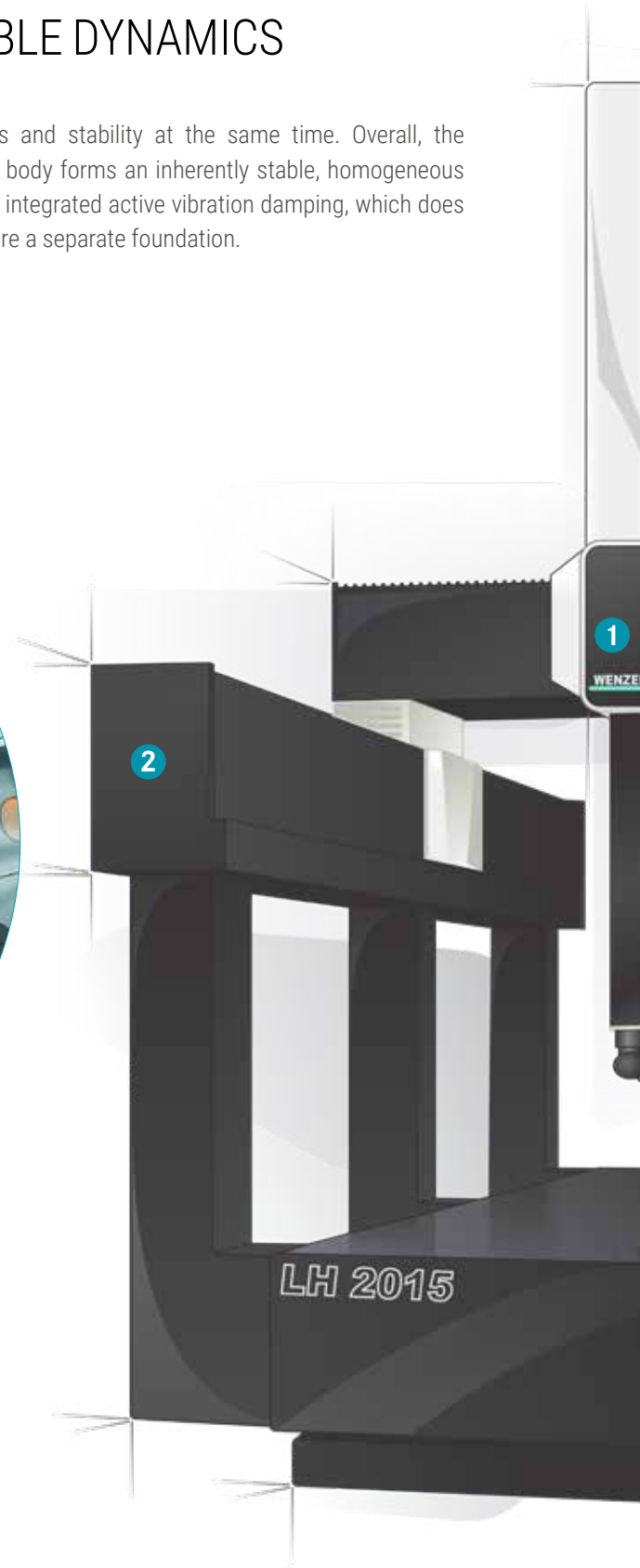

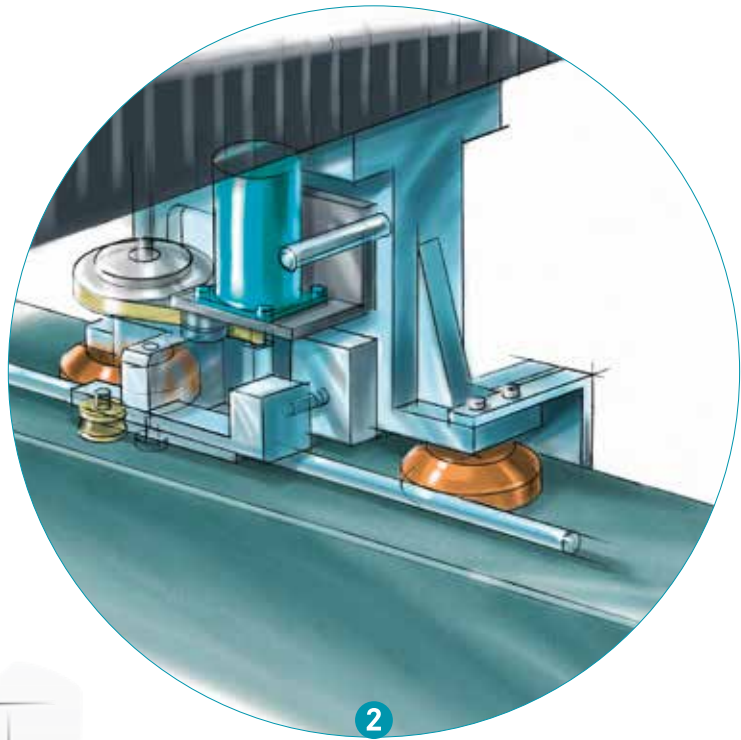

Double drive in the Y-axis for LH 2015

- High dynamic

WENZEL LHF SERIES

LARGE MEASURING RANGE AND EXCELLENT ACCESSIBILITY

Wide measuring range and excellent accessibility. The LHF is a CNC coordinate measuring machine with air bearings on guide beams, which has been designed for high-precision measurement of large-volume and complex workpieces. Its ground-level design allows excellent access to a large measuring range with maximum freedom of movement. The measuring range in the Y-axis is available in the standard version up to a length of

12 meters. A double drive in the Y-axis of the LHF makes it unbeatable in terms of dynamics. The thermal influences of the environment on the machine and workpiece can optionally be corrected by means of automatic temperature compensation. LHF series measuring machines are available in the accuracy classes Standard, Premium and Premium Select.

FEATURES

- **Optimum stability** due to intrinsically stable guide beams and precisely dimensioned air bearings
- **High performance** even with large extensions, eccentric loads and scanning with REVO at high speed
- **Best position stability** due to incremental displacement measuring systems with precision scales and excellent contamination tolerance
- **High dynamics** due to double drive in the Y-axis and backlash-free friction drives
- **Easy maintenance** due to high availability of spare parts and easily accessible replacement components

FIELDS OF APPLICATION

The WENZEL LHF is designed for high-precision measurement of large-volume and complex workpieces. It is used by innovative medium-sized companies as well as world-famous large corporations - or simply everywhere where high measuring requirements define the requirement.





MEASURING ACCURACY

Type	Measuring ranges X x Y x Z (mm)	Volumetric length measuring uncertainty $E_{L, MPE}$ (μm) Premium Select
LHF 2517	2500 x 4000/5000/6000 x 1700	3,5 + L / 400
LHF 3020	3000 x 4000/5000/6000 x 2000	4,3 + L / 400
LHF 3025	3000 x 5000/6000 x 2500	5,2 + L / 400
LHF 4025	4000 x 5000/6000 x 2500	7,0 + L / 400

Value $E_{L, MPE}$ only valid for SP80/SP25M/REVO touch probes.

Other Y-lengths on request. Subject to changes in design and scope of delivery as well as further technical development.

YOUR ADVANTAGES AT A GLANCE

- Long term, mechanical accuracy**
 Temperature stable structure | Hand finished |
 Air bearing guide elements in all axes
- Low cost of ownership**
 Low air consumption | Reliable and cheap replacement
 parts | Less effort in recalibration
- High flexibility**
 Special measuring sizes on request | Data compatibility
 with other WENZEL systems | Loading systems |
 Automation solutions
- Various sensor options**
 Touch trigger probes | 3- or 5-axis scanning |
 Optical sensors
- Ergonomic design**
 Easy to use | Easy to service | Easy to load

THE LHF-FEATURES

EASY ASSEMBLY FOR LARGE PARTS

Air bearings on the guide beam in the Y-axis. The ground-level design of the LHF allows excellent access to a large measuring range with maximum freedom of movement. A double drive in the Y-axis of the LHF makes it unbeatable in terms of dynamics; and that with unique stability of the guides. Similar to the LH-Gantry, the LHF air bearing guide elements also guarantee wear-free operation with precise guidance. Crossbeam and guide beam are made of dark

natural hard stone, so that all axes have the same thermal behaviour. As this type of device does not have a stable base plate, an inherently stable foundation is required. With a normal soil ratio, a passively damped foundation is sufficient. In case of strong vibrations, vibration damping elements in the foundation are necessary.

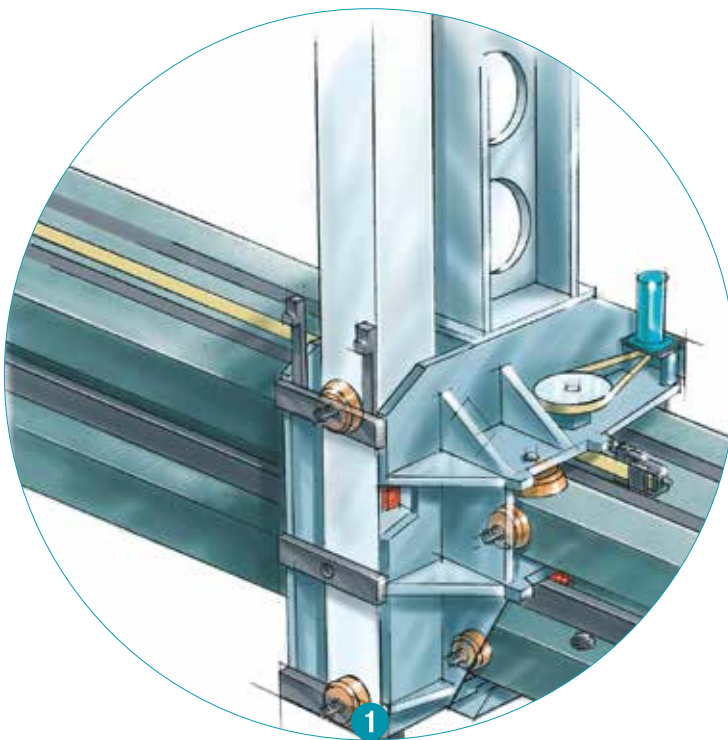

Symmetry everywhere

- Optimized air bearing with "broad base"
- Perfection in detail
- Service friendliness
- Thermal stability
- Optimized air bearing guidance in double T-shape

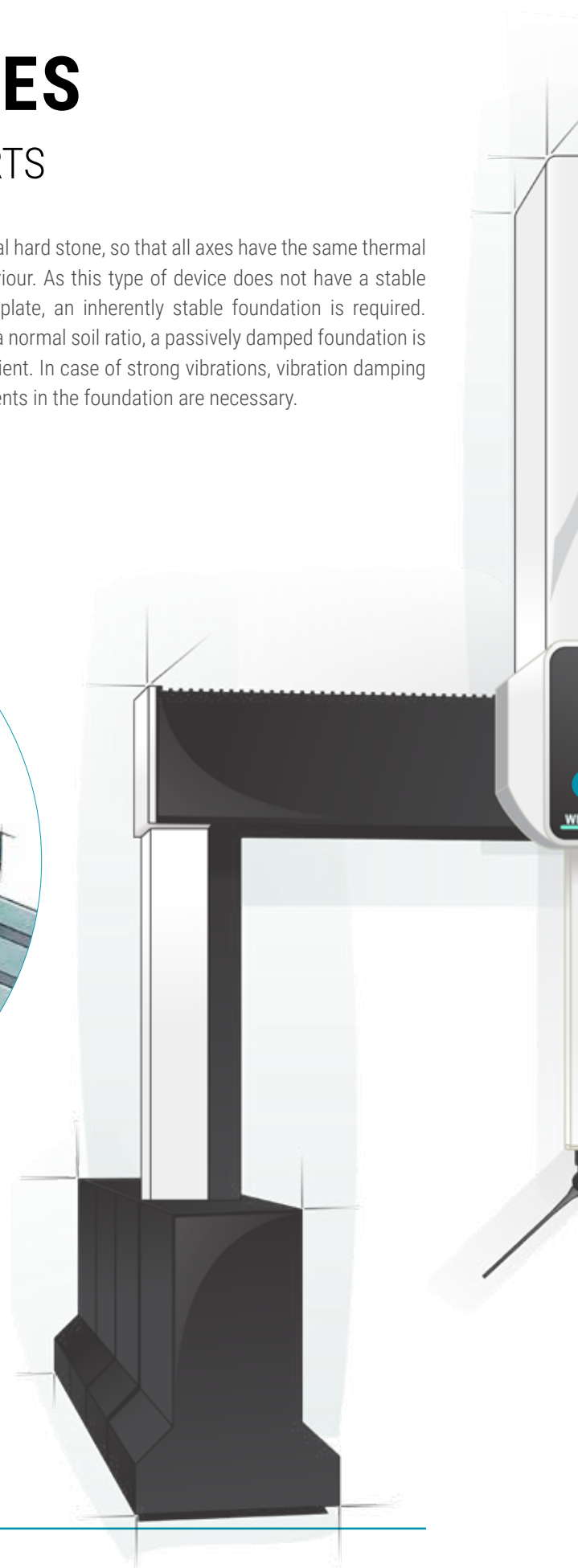

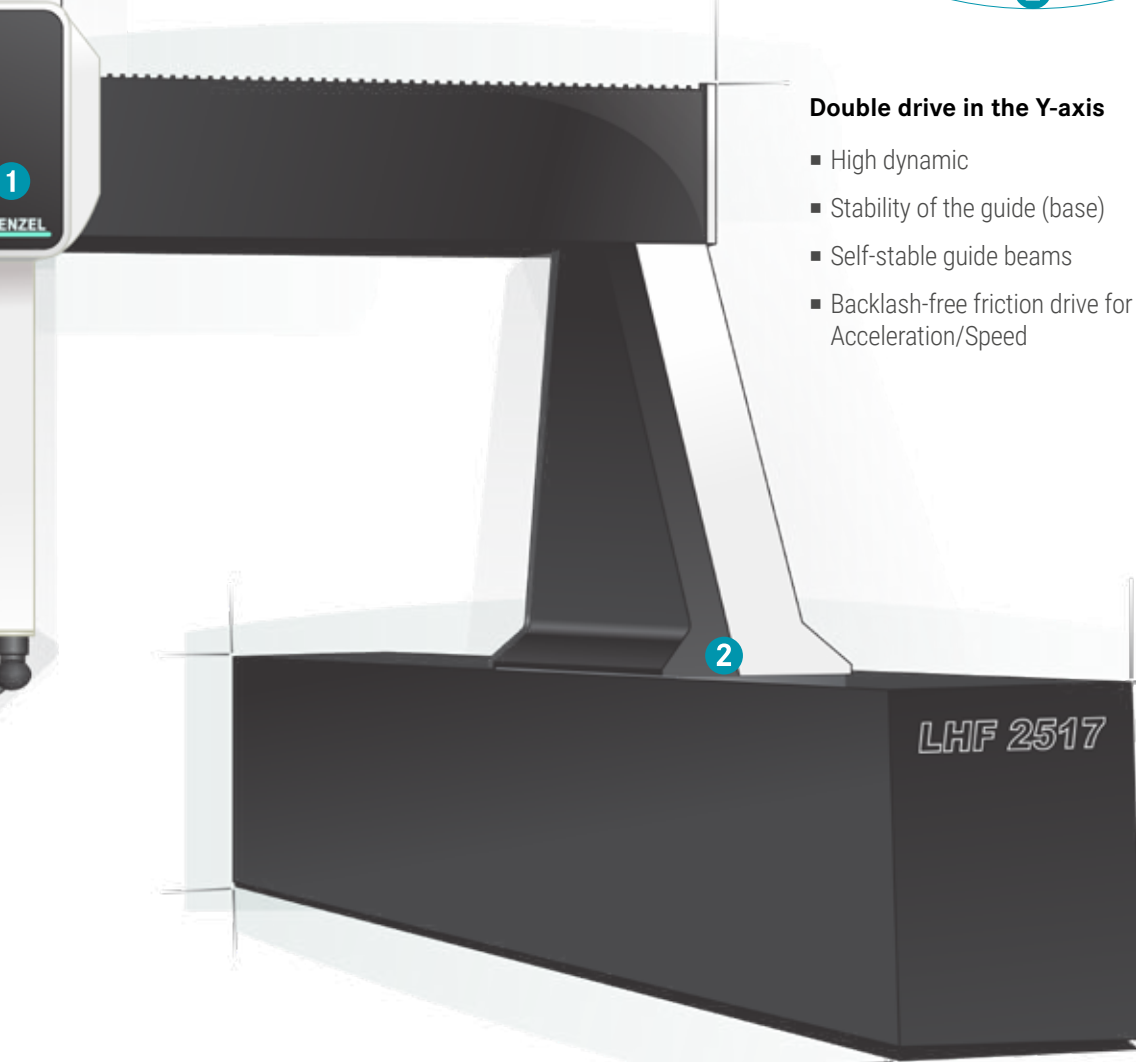
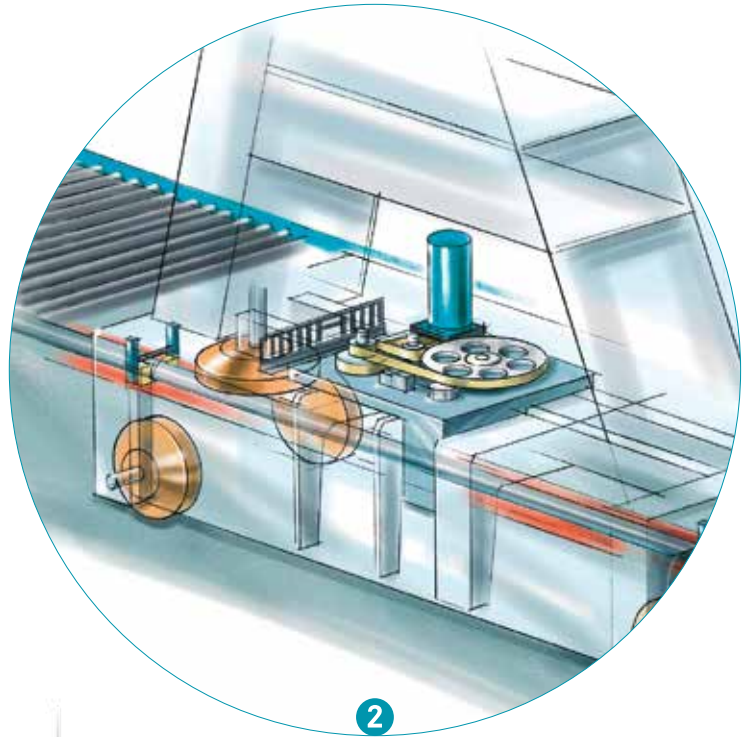

Double drive in the Y-axis

- High dynamic
- Stability of the guide (base)
- Self-stable guide beams
- Backlash-free friction drive for maximum Acceleration/Speed

THE LH SERIES WITH ROTARY TABLE

FULL FLEXIBILITY FOR EVERY MEASURING TASK

All measuring machines of the LH series can be configured with an additional integrated rotary table. This enables both the precise 4-axis measurement of rotationally symmetrical components and the reliable measurement of the entire spectrum of prismatic components. The base plate and linear axes are made of temperature-stable materials. This ensures excellent temperature behavior

of the entire measuring system. In order to guarantee the highest precision, air bearings are used in all axes. The optimum measuring system can be configured according to component size, component weight and measurement requirements. Different mounting heads and touch probes allow an optimal adjustment to your measuring requirements.

FEATURES

- **High accuracy** due to identical thermal behavior of the granite in all axes
- **Excellent long-term stability** due to air bearing guides incorporated into the granite base plate and high-precision lapped guide surfaces
- **Extreme wear resistance** and freedom from residual stresses thanks to high-quality granite components
- **Excellent durability** based on innovative drive, bearing and guidance technologies
- **High-resolution scales** ensure exact positioning and precise measurement results
- **WM | Gear Analyzer** software based on the open GDE standard allows numerous measurement and evaluation options

FIELDS OF APPLICATION

The LH series with rotary table quickly and reliably measures rotationally symmetrical as well as prismatic precision components. The numerous models and equipment options allow optimum adaptation to your measuring requirements.

Gears



Bearings and couplings



Shafts and axes



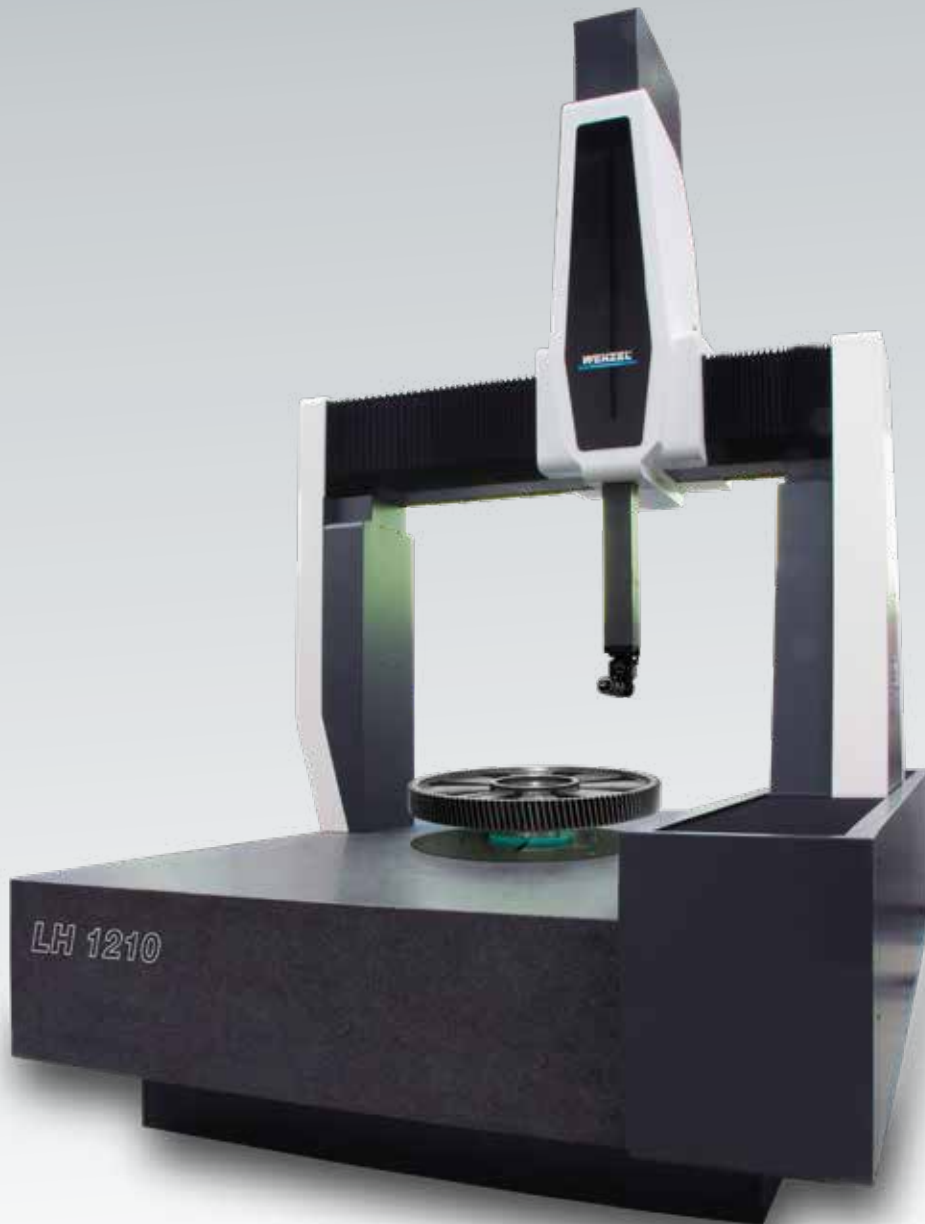

YOUR ADVANTAGES AT A GLANCE

■ High mechanical precision

Granite base | Handcrafted | Precise air bearings in the linear axes

■ Low operating costs

Low air consumption | Reliable and inexpensive spare parts

■ Impressive speeds

4 axes for ultimate speed and precision | Fully automatic probe changing systems

■ High flexibility

Measurement of rotationally symmetrical as well as prismatic components with just one system | Numerous sizes and configurations

■ High reliability

High-quality components | Many years of development experience | Renishaw sensor systems

WM | Quartis

AUTOMATED MEASUREMENT & EVALUATION

WM | Quartis is the versatile, reliable, modern and easy to use measurement software from WENZEL. With WM | Quartis WENZEL offers a new generation of innovative measurement software with a clear, flexible and result-oriented user interface for all industrial applications. Meaningful measurement reports can be generated even faster and easier. The user interface of WM | Quartis, based on Microsoft Office Fluent, significantly simplifies the application of the powerful functions.

You can obtain correct measurement results, impressive test reports and meaningful statistics more quickly and easily. The optimized screen layout and the dynamic, result-oriented ribbons significantly speed up workflows and ensure greater efficiency in day-to-day business. In combination with the WENZEL software products WM | PointMaster or WM | CT Analyzer, WM | Quartis is also able to generate traditional measurement reports from point clouds and CT data.

FEATURES

- **Geometry, freeform** and **curves** combined in one measuring software
- Scanning with **tactile and optical sensors** and **5-axis measuring heads**
- Form and position evaluation according to the latest **ISO GPS** and **ASME standards**
- **DMIS 5.2 Standard** complements the intuitive Quartis programming language
- **Structured data management** in relational database (MS Access / SQL-Server)
- **Report generator** for descriptive measurement reports

HIGHLIGHTS

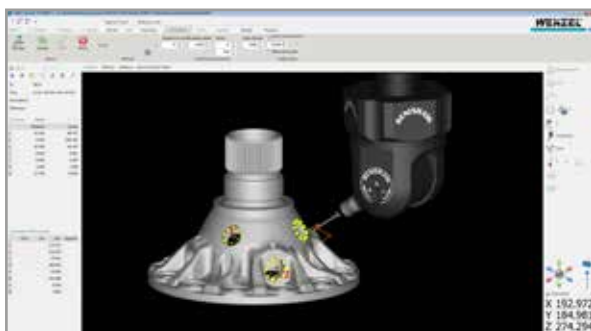

Universal measuring software

One solution for all tasks

A software for measuring and evaluating geometry, freeform and curves. 5-axis REVO and PH20 probes increase measurement throughput and allow measurement of roughness. Automatic creation of measuring programs as well as efficient teach-in offline and directly at the coordinate measuring machine. Universal measuring device interfaces (I++ DME).

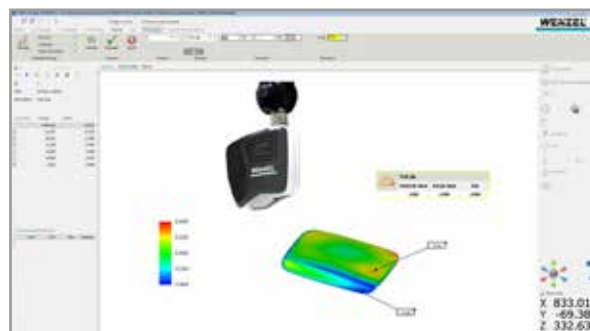

Optical measurement

Measuring at the speed of light

With the 3D line scanner WENZEL Shapetracer surfaces are automatically scanned on tactile components. The comparison of the point clouds to the CAD model shows the deviations. Export of point clouds for optional further processing in WM | PointMaster.

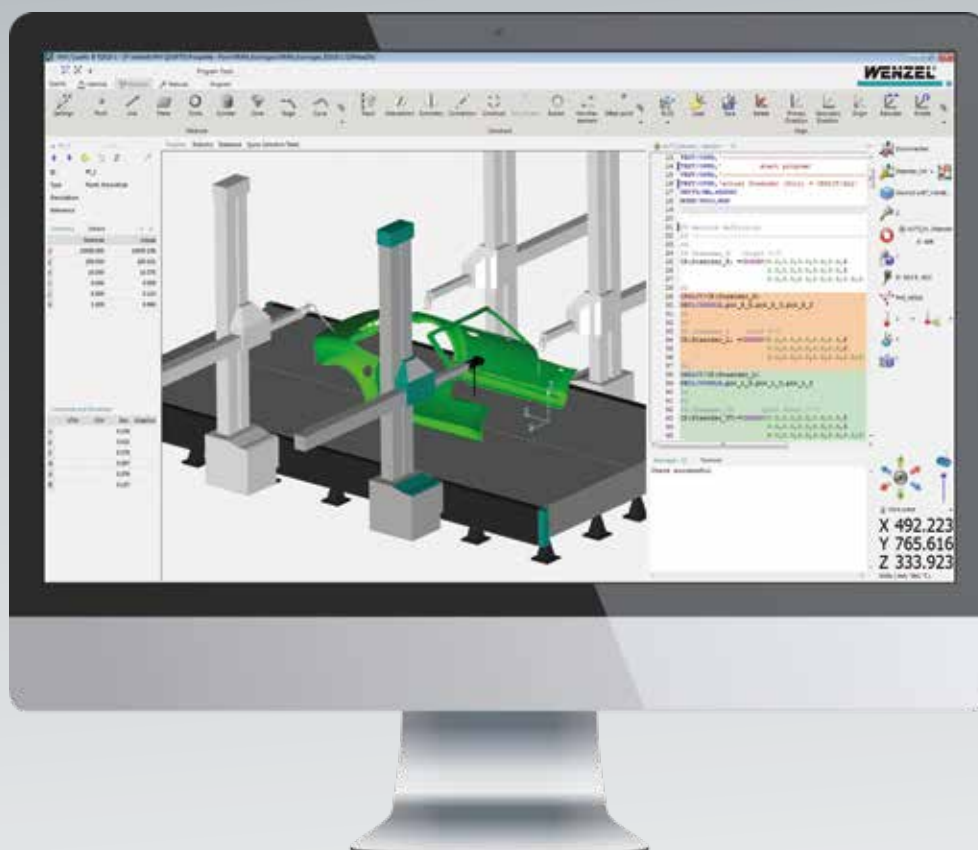

User interface

Suitable for every task

The easy-to-use, task-oriented and individually configurable graphical user interface is suitable for every measuring task. The measuring programs can be started quickly and easily with just one click via the quick selection panel or by using of a barcode scanner. The relational database also ensures traceable measurement results. The integrated statistics package guarantees a rapid assessment of manufacturing processes. The CAD functionality of WM | Quartis is the basis for efficient measurement. The integrated live preview ensures a correct application of the standard-compliant evaluation according to ISO GPS and ASME.

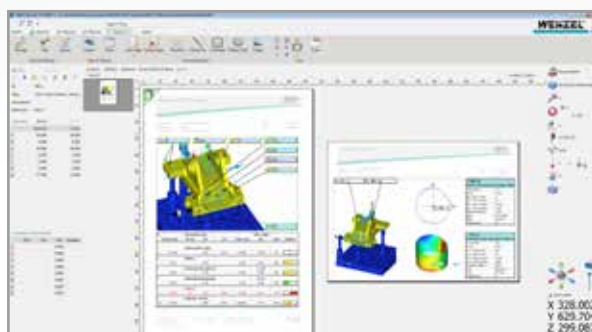

Clear measurement reports

Everything at a glance

The integrated report generator allows a free design of the measurement reports (table and graphic views with freely configurable data and statistics boxes). Deviations can be displayed color-coded. WM | Quartis also offers various export options (PDF, ASCII, Excel).

YOUR BENEFITS AT A GLANCE

- Swiss Made**
 Reliable | Precise | Regular updates
- Simple operation**
 User-friendly Microsoft Fluent Interface | Dynamic Ribbons | Structured Workspace
- Low operating costs**
 Software maintenance contract at a reasonable price | Volume discounts | Low training costs
- Powerful universal software**
 Offline programming | Complete simulation | Multi-column measuring systems | Virtual measurement on scan and CT data
- Connectivity**
 Imports from all common CAD systems | Data transfer to external statistical software, e.g. qs-STAT from Q-DAS | Automation solutions

EVALUATION SYSTEMS AND ACCESSORIES

PRECISION IN DETAIL



WENZEL Evaluation Station

- Compact workstation with integrated media supply
- Mounting the WENZEL CNC-Controller
- Housing of the evaluation PC system in desk form (120 cm x 90 cm) 19" technology

WENZEL evaluation system CNC

- Optimized machine performance
- Optimized for WENZEL & Renishaw sensors
- Scanning button possible via option cards

Interfaces WPC2040

- Ethernet
- RS232
- Readerhead input (5V TTL)
- Push-button input (5V TTL)
- Motor connections



Standard control panel HT400, wired

- Ergonomic shape for one-handed operation
- 1 joystick for all axes
- Multifunction pad
- Stepless adjustment of the CNC travel speed
- Emergency stop function according to EN 60204 and EN ISO 13850

Wireless control panel HT400RC

- Wireless control panel HT400RC incl. receiver
- 1 charging cable each 0.5 and 6.0 m
- Charging station and spare battery
- Power supply



Styli

Comprehensive range of styli for every application

The accessories shown here are only a small selection from our extensive product range.

For further information please contact your local WENZEL representative.

TECHNOLOGY AND SUPPORT

THE LH CMM IN DETAIL



Guarantors for stable results

Active damping

The LH Series can optionally be equipped with a pneumatic active damping system, which protects the CMM from external vibrations and kinematic influences.

Thermal compensation

The LH Series can be equipped with automatic temperature compensation. Thus, the measuring device and work piece are protected against the thermal influences of the environment.



Service and application support - We are there for you

Professional user training

Training can be offered as individual training, group training and seminars. The Training can be performed at your facility or at your WENZEL technical center.

Qualified service team

Our service team is there to assist you: For repairs, maintenance, retrofitting and telephone support or with WENZEL Online Service (WOS) - the Internet-based remote diagnostics and remote maintenance service.



Granite: CMM Material No. 1

For air-bearing bridge measuring instruments, base plates as well as traverses and quills are usually made of granite. Its physical properties make granite the perfect material for measuring instruments. WENZEL carries out all processing steps from cutting to size, milling, grinding and lapping of the granite itself. Although aluminium creates the feeling of being lighter than granite, its specific weight is hardly lower in reality. The coefficient of expansion of aluminium however, is almost four times greater.

Physical properties of materials in metrology

Material	Specific weight [kg/dm ³]	Coefficient of expansion [1/K]	Temperature expansion [W/mK]	Modulus of elasticity [10 ⁹ N/mm ²]
Steel	7,25	10,4*10 ⁻⁶	42-63	90-180
Aluminium	2,7	23,8*10 ⁻⁶	210	72
Ceramic (Al2O3)	3,85	8*10 ⁻⁶	28	370
Granit	2,8	6,5*10⁻⁶	3,5	NIL



High resolution scales

Accurate positioning thanks to the optimal position measuring system technology

The LH Series is equipped with an incremental measuring system, which has very fine scale pitch, and excellent dirt immunity.

Thus, the best position resolution and stability at high speed in all linear axes is possible. The highly precise and robust scale tapes compensate inherent hysteresis.

SENSORS AND CHANGER RACKS

PROBE HEADS, PROBE SYSTEMS AND SCANNERS

When combined with a variety of innovative sensors the LH Series is a flexible solution for a number of different applications. From the smallest injection molded parts up to large sheet metal forming dies – the LH CMM meets your needs! The LH Series can be equipped with both, manual and motorized probe heads as well as continuously recording systems and indexable probe

heads. With suitable touch trigger, scanning and optical measurement systems LH CMM offers outstanding results for various applications.

The compatible automatic exchange units turn the measuring instruments into homogeneous and versatile measuring systems.



PH10T PLUS / PH10M PLUS / PH10M iQ PLUS

Automatically indexable probe head PH10M: Fast probe replacement (auto joint) with the corresponding change systems.

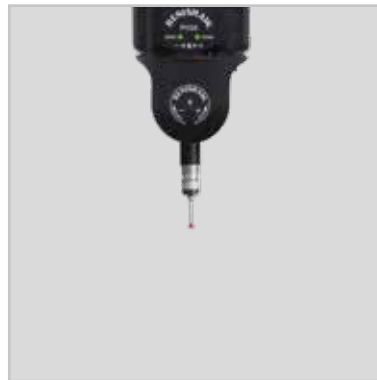

PH20

The 5-axis PH20 and LH are an efficient solution for measuring 3D and prismatic components. The 'Head Touch' function takes measurement points very quickly and reduces cycle times.



REVO-2

The revolutionary 5-axis probe system REVO™ coupled with WM | QUARTIS provides an extremely fast high scanning speed solution with a high degree of measurement flexibility, and thus an extremely high throughput.



TP20

Touch trigger probe. Extremely robust and flexible touch trigger probe.



TP200

Compact, module changing touch trigger probe particularly suitable for measuring tasks with tight dimensional tolerances for 3D free-form surfaces with longer styli.



SP25M

The most compact and versatile probe system for scanning on a global scale.

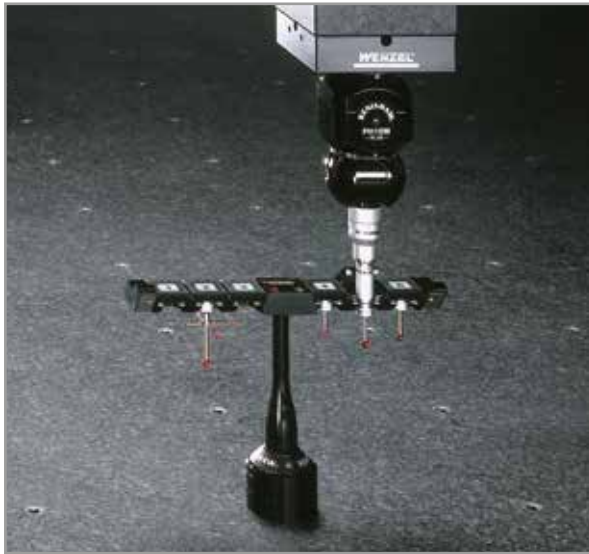

Changer Rack SCR200

With the SCR200 change magazine, up to six TP200 stylus modules can be changed quickly and automatically. The SCR200 is controlled by a separate interface (PI 200) and has collision protection against mechanical damage.



Changer Rack ACR3

The ACR3 probe changing system allows automatic probe change without the need for recalibration. Although the ACR3 is a unit with four memory locations, several systems can be connected to each other in such a way that further different measuring probes and probe extensions can be accommodated in it.



Changer Rack FCR25

Flexible changing system for automatic changing of SP25M scanning and probe modules with 3 stations (6, 9, 12 and 15 stations possible).



MRS2 modular rack system

MRS2 is available with different column and rail lengths to allow configurations for a variety of applications. When the CMM workspace is tight, or when a large number of probes and styli are needed, additional rails can be attached to the MRS2 to configure a multi-stage magazine. The rail is compatible with the following interchangeable systems: ACR3, FCR25, memory module and roughness probe SFA for REVO probes.

μ-ACCURATE MEASUREMENT OF BIG PARTS

What used to be the exception has become increasingly the norm over the last five or six years in the measurement of manufactured parts. The trend is clearly towards 100% control. The company Tool-Tec from Pischelsdorf is well prepared for these "high customer demands". The company recently invested in another gantry-type coordinate measuring machine. The WENZEL LH 2015 was ordered from GGW Gruber, Tool-Tec's trusted partner for high-precision, quality-assurance testing.

Tool-Tec was actually founded in 1993 as a toolmaker, but the market gave the Styrians a different direction. Meanwhile the Pischelsdorfer are regarded as the go-to people when large parts have to be turned, milled and/or welded. "We offer our customers tailor-made complete solutions from a single source, whereby a few years ago we specialized in the machining of large parts," reveals Harald Wolf, founder and managing director of Tool-Tec Werkzeugbau GmbH. Among the Steirer's regular customers are many well-known mechanical engineers and industrial companies. Typical products ordered from Harald Wolf and his team of 85 employees are, for example, machine base frames including painting. An average annual quantity of 400 means that two such machine components are produced almost daily.

"We can weld, process and measure parts with a unit weight of up to 15 tons", emphasizes the Tool-Tec boss. "When welding, we meet the requirements of DIN EN 15085 CL1/CL4-2, DIN EN ISO 3834-2 and EN 1090," he adds. The approval for the welding of rail vehicles and rail vehicle parts is therefore also given by the Pischelsdorfer.

KEY DATA ON THE PROJECT

Customer:

Specialist in the machining of large parts - turning, milling and welding of components with a unit weight of up to 15 tons.

Requirements:

Tailor-made complete solutions from a single source.

- Machine base frame including painting.
- Welding of railway vehicles and parts.

Fields of application:

Zero defect policy with quality assurance according to ISO 9001 and ISO 14001.

- Just-in-time delivery and with test report
- Process control and optimization

Quality assurance is the trump card

The company Tool-Tec's machinery is impressive. A total of 20 CNC milling machining centers, three lathes, two grinding machines, five welding machines, one painting booth and two measuring machines distributed over two locations are available for mainly series production. Usually the ordered lot sizes range between 5 and 50 pieces. "We strive for lasting customer relationships and impeccable references. To this end, we pursue a zero-defect policy with quality assurance in accordance with ISO 9001 and ISO 14001," explains Harald Wolf. The demands of our customers are constantly increasing. According to the Tool-Tec managing director, this fact can be seen, among other things, in the fact that just-in-time delivery with test reports is becoming increasingly necessary. "What used to be the exception is now explicitly included in almost every order: most customers want to have their documents documented in black and white and



Perfect teamwork: Walter Artinger (right), workshop manager at Tool-Tec, knows that he can always contact Roland Widrich (left) and his colleagues at GGW Gruber if he has any problems or questions.

proof that the quality of the manufactured parts fits 100%," confirms Harald Wolf. That was one of the reasons why he recently invested in another WENZEL LH Gantry. The LH 1210, which has been available for a long time, has already been performing reliable "measuring services" at the Pischelsdorf company for several years. "This coordinate measuring machine has already pointed out errors to us several times. It serves not only as a quality assurance tool but also as a quality-enhancing instrument, because we can now optimize much more specifically," says one who prefers to act proactively. After all, as a future-oriented company interested in long-term success, it has to stay on the ball permanently in order to succeed in the face of increasingly global competition.

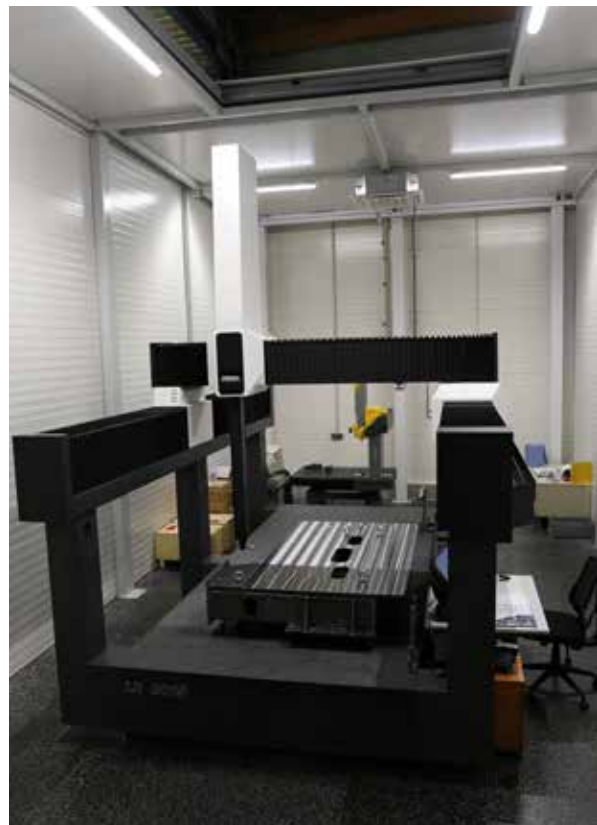

Upstairs there is room for the overhead travelling crane: Without a crane nothing is possible with the parts weighing up to 15 tons that are measured in this WENZEL system.

μ-ACCURATE MEASUREMENT OF BIG PARTS

LH 2015 as unique selling point

It only moved into Tool-Tec in February 2018, but many potential customers knew about it within a very short time: "Things like this get around quickly," smiles Harald Wolf. He remembers several phone calls that started in the last months with the words "I heard you have a new measuring machine...". No wonder, because such a 3D coordinate measuring machine of gantry construction, with which one can measure up to 2 m wide, 4 m long and 1.5 m high parts μ-precisely, is already a certain unique selling point. Not everyone has that.

The LH Gantry is a CNC coordinate measuring machine with air bearings in all axes. It offers all the advantages and applications of the LH series and has been specially designed for the inspection of large-volume and heavy workpieces. "Thanks to the granite construction the LH Gantry scores with a very high basic accuracy. It is extremely long term and temperature stable. Thermal environmental influences acting on the workpiece and the CMM are corrected by automatic temperature compensation. Another optionally available special feature that has actually been integrated into the Tool-Tec solution is the active pneumatic vibration damping, which provides optimum protection against vibration," describes Roland Widrich, Sales Manager Austria at GGW Gruber.

Scanning rotary/tilt switch

For Harald Wolf, it was actually clear from the very beginning that the new measuring machine would again be "a WENZEL": "On the one hand, the LH 1210, which has been available for a long time, has been working perfectly for years, and on the other hand, we received consistently positive feedback when we asked other users about their experiences with this CMM. Last but not least, the support provided by GGW Gruber is also excellent: "Whenever there is a measuring problem, it is solved professionally within the shortest possible time," he praises.

"I often turn to Mr. Widrich and his colleagues for detailed programming questions," says Walter Artinger, workshop manager at Tool-Tec. The Styrian is extremely pleased that quality assurance and thus the LH 2015, among other things, are now also part of his area of responsibility: "I actually come from milling and working with this CNC coordinate measuring machine represents a new challenge for me. It's like a little Mercedes," he compares. "I haven't found any weaknesses with this machine yet and the service from GGW Gruber is also perfect," he adds.

One probe for all positions - that means flexibility. Within a very short period of time, tens of mea





“The LH 2015 is like a small Mercedes. I haven’t found any weaknesses with this machine yet and the service from GGW Gruber fits perfectly, too.”

Walter Artinger, Workshop Manager at Tool-Tec

measuring points are picked up and recorded by a scanning rotary/tilt probe.

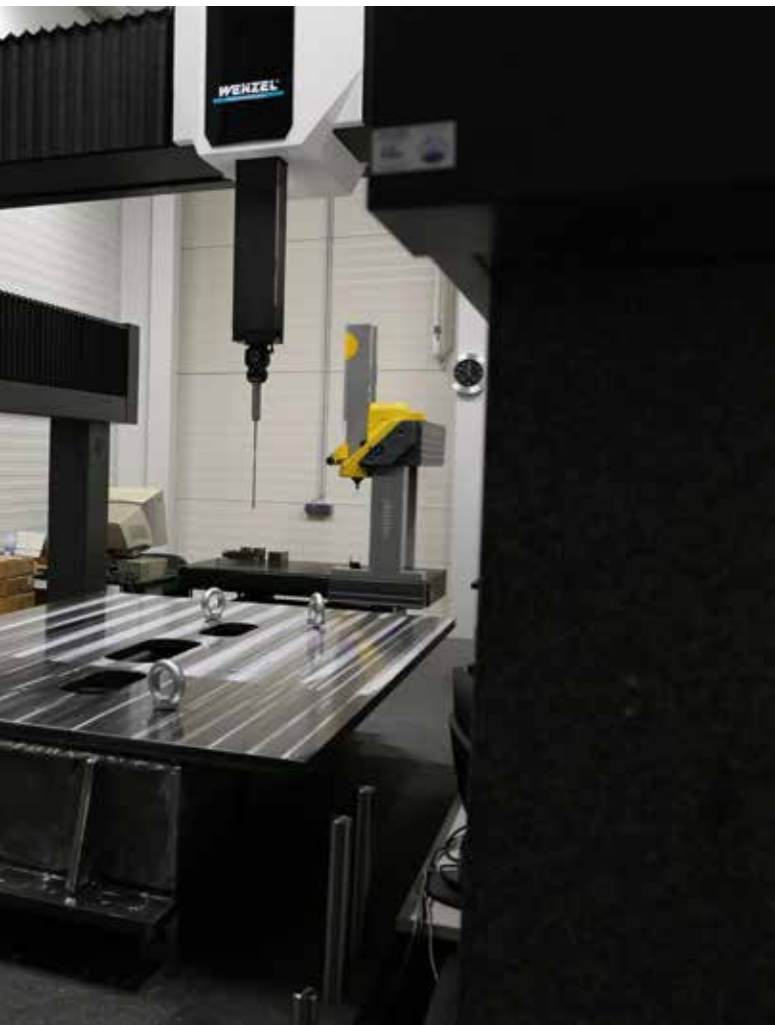

un to learn how to place the workpieces to be measured in the LH Gantry to get the scanning probe to the desired location. Because one thing is “law” at Tool-Tec: no product leaves the company without having been carefully examined in an LH Gantry. During this quality check, not only the most varied dimensions, distances and tolerances are checked, but also fits, position positions and much more. An average measurement log shows between 50 and 100 positions, the complete geometry of each individual component is precisely measured at 2 μ . A scanning rotary/tilt switch that can be tilted from 0 to 360 ° and from 0 to 105 ° in 720 positions makes this possible. “One button for all positions - that means flexibility. Throughout the scanning, this not only works very accurately, but also very quickly. Within the shortest time, dozens of measuring points are recorded and captured”, Roland Widrich finally emphasizes the efficiency of the WENZEL 3D Gantry measuring device solution used at Tool-Tec.

CUSTOMER PORTRAIT

Founded in 1993, Tool-Tec Werkzeugbau GmbH developed over the years from a two-man business to a company with 85 employees. Whereby the Pischelsdorfer have finally specialized in the processing of large parts. Among the Steirer’s regular customers are many well-known mechanical engineers and industrial companies.

Tool-Tec Werkzeugbau GmbH, Pischelsdorf 411,
A-8212 Pischelsdorf am Kulm, Tel. +43 3113/3488-0,
www.tool-tec.at

INNOVATION MEETS TRADITION

The WENZEL Group is a market leader in innovative Metrology. WENZEL offers a comprehensive product portfolio in the fields of Coordinate Metrology, Computed Tomography and Optical High Speed Scanning. The technology of WENZEL is used in all industries, including the automotive sector, aeronautics, power generation and

medicine. WENZEL looks at today on an installed base of more than 10,000 machines worldwide. Subsidiaries and agencies in more than 50 countries support sales and provide after-sales service for our customers. The WENZEL Group today employs more than 600 people.



YOUR LOCAL CONTACT PERSON

WENZEL GROUP GMBH & CO. KG

Werner-Wenzel-Straße

97859 Wiesthal

Phone: +49 6020 201-6006

E-Mail: sales@wenzel-group.com

We are there for you worldwide. You can find our subsidiaries, sales and service partners at www.wenzel-group.com.

Follow us & stay up to date!

